

Operating and installation instruction SunFurl[®] RES (Rev. 01/2023)

Awning system I Type RES I electric drive

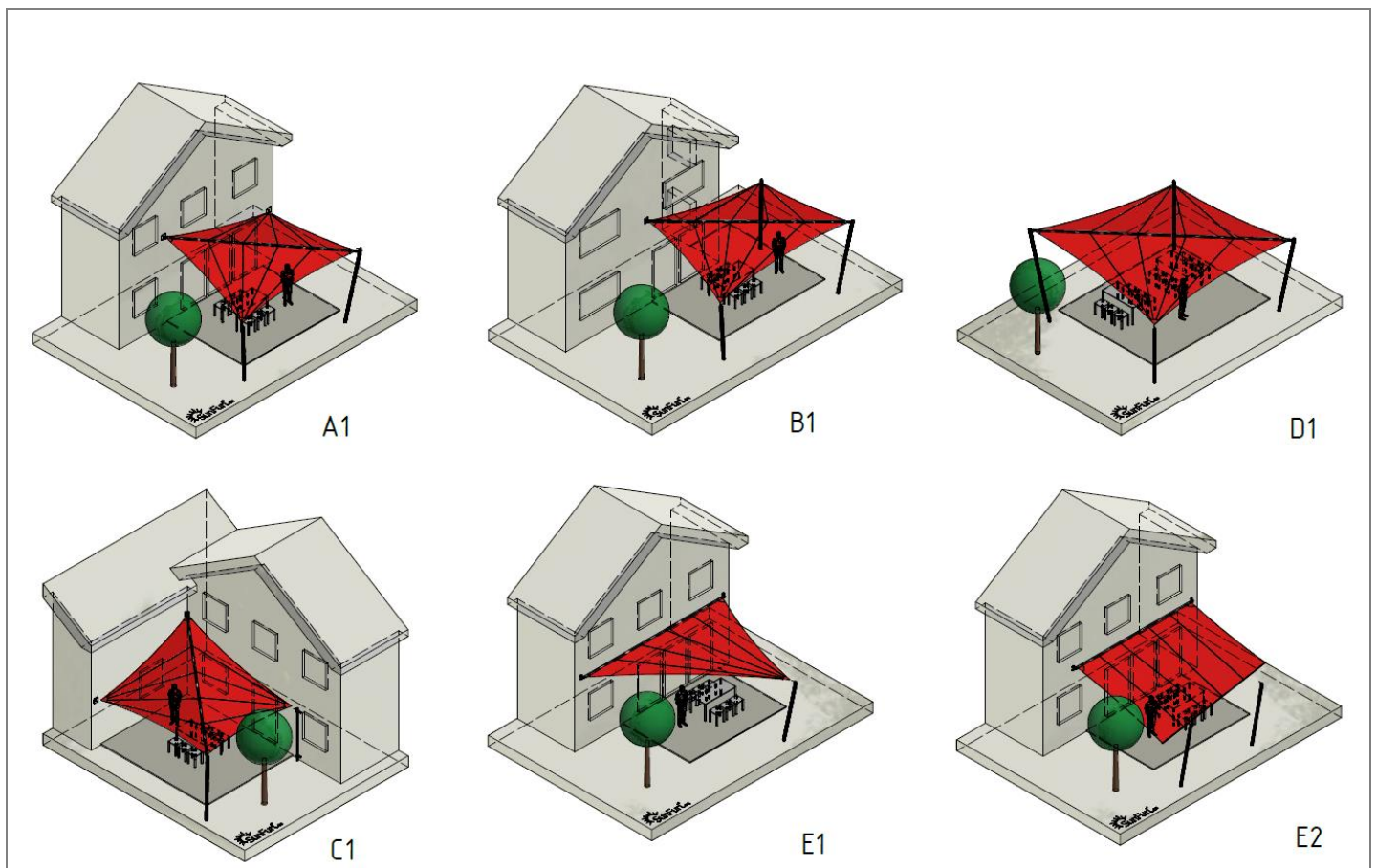

Imprint

Responsible for the content:

BARTELS GmbH
Keltenschanze 5
88677 Markdorf - GERMANY

Tel: +49 (0) 7544/ 95860-0
Fax: +49 (0) 7544/ 95860-60
E-mail: info@bartels.eu
Web: www.bartels.eu

Reproduction of this document in whole or in part is not permitted without the express consent of BARTELS GmbH!

www.bartels.eu

1 Table of contents

1	Table of contents	1-3
2	General	2-5
2.1	The Product (<i>electric awning system SunFurl® RES</i>)	2-5
2.2	Intended use / operation	2-5
2.3	Delivery	2-6
2.3.1	Furling core incl. Mounting elements	2-6
2.3.2	Standard mounting elements	2-7
3	Safety	3-10
3.1	General safety	3-10
3.1.1	Signal words and warning symbols used	3-10
3.1.2	Guidelines and standards	3-10
3.2	Safety instructions for the operator	3-11
3.2.1	Guidelines and standards	3-11
3.2.2	Occupational safety	3-11
3.2.3	Technical condition of the product	3-11
3.3	Safety instructions for the operating personnel	3-12
3.3.1	Personnel to be assigned and qualification	3-12
3.3.2	Danger spots and possible accident hazards	3-12
3.4	Specific components (Safety instructions)	3-14
3.4.1	Safety devices / main switch	3-14
3.4.2	Safety and warning labels	3-14
3.5	Specific energy systems (Safety instructions)	3-15
3.5.1	Electric / Gas spring	3-15
3.6	specific lifecycle of the product (Safety instructions)	3-16
3.6.1	Transport	3-16
3.6.2	Installation/ Assembly	3-16
3.6.3	Service and maintenance	3-16
3.6.4	Dissassembly and Disposal	3-16
3.7	Safety instructions for materials and supplies	3-17
3.7.1	Materials used and surface coatings	3-17
3.7.2	Oils / Greases	3-17
4	Product description	4-18
4.1	Name of the product	4-18
4.2	Controls	4-18
4.3	Overview of the product and its components and connections	4-19
5	Installation	5-23
5.1	Unpacking / transporting of the product	5-23
5.2	Assemble the product	5-23
5.3	Mast securing	5-25
5.4	Fill in the dimension sheet	5-29
5.5	Notes on the measurement sheet	5-31
5.6	Measurement sheet "measure around the corner"	5-32
5.7	Connect the product to the power supply	5-33
6	Commissioning	6-34
6.1	Preparatory work for switching on the rolling mechanism	6-34
6.2	Switching on the product (with Solexa radio control)	6-34





6.3	Setting up / adjusting the product	6-35
6.3.1	Adjust the limit switch / retract the sail	6-35
6.3.2	Threading the rope into the rope store	6-37
6.4	Winter Protection Cover.....	6-39
6.5	Stop and switch off the product	6-40
7	Operation	7-41
7.1	Switch on the system.....	7-41
7.2	Operating the system.....	7-41
7.3	Restart the system after an interruption	7-41
7.4	Stopping / switching off the system	7-41
8	Fault states	8-42
8.1	Errors / error causes / trouble shooting	8-42
9	Maintenance	9-43
9.1	Maintenance instructions for your safety	9-43
9.2	Maintenance after switching off the system.....	9-43
10	Decommissioning, disposal.....	10-44
10.1	Decommissioning, disassembly and storage.....	10-44
10.2	Recommissioning after shutdown	10-45
10.3	Disposal after disassembly	10-45
11	Warranty	11-46
11.1	Warranty Period	11-46
11.2	Wear parts.....	11-46
11.3	Disclaimer	11-46
11.4	Processing of a warranty claim	11-46
12	Attachment.....	12-47
12.1	Arrangement plan.....	12-47
12.2	Forces / Fasteners	12-47
12.2.1	Forces / General.....	12-47
12.2.2	Forces on wall plates.....	12-49
12.2.3	Select dowels and screws for wall fixings correctly.....	12-50
12.3	Circuit diagram SunFurl pipe ® 230V	12-51
12.4	Operating instructions for 3rd party components.....	12-52
12.4.1	Tube drive 230V AC (L70/17.L80/11 E23 Fa. Becker).....	12-52
12.4.2	SOLEXA sensor control / radio control.....	12-52
13	EG – Declaration of conformity	13-53

2 General

2.1 The Product (*electric awning system SunFurl® RES*)

	<p>SunFurl® stands for high-quality and individually planned sun sail systems. Each SunFurl® awning system is individually planned by trained specialist dealers according to customer requirements and the structural conditions.</p> <p>An aluminum core with an internal drive and integrated Keder grooves is used as the winding axis. The lines are guided fully automatically. Line storage elements in the masts ensure that the sails are always taut. A wind and rain guard is always active and protects the furling mechanism, sail and attachment points from excessive stress caused by fresh winds or heavy rain. It is operated conveniently via a radio module. Sail areas of up to 100 m² can be easily realized with the standard systems.</p> <p>All BARTELS products are characterized by a robust design and extremely high-quality workmanship. Only weather-resistant materials (stainless steel, aluminium, bronze) are used. The sails are individually manufactured by experienced sailmakers from high-quality materials.</p>
--	--

2.2 Intended use / operation

	<p>The SunFurl® RES system (furling core, masts, floor and wall fastenings, sails, weather control) is designed for use as a shade sail / awning system.</p> <ul style="list-style-type: none"> • Length of the aluminum Furling core max. 9 m with a D86 shaft / max. 14 m with a D102 shaft • Sail area max. 100m² • Sail extension length max. 7.5 m • Up to 9m D86 shaft > 6 Bft (max. 45 km/h or 12.5 m/s) • Up to 10m D102 shaft > 6 Bft (max. 45 km/h or 12.5 m/s) • Up to 12m D102 shaft > 5 Bft (max. 35 km/h or 10.7 m/s) • Up to 14m D102 shaft > 4 Bft (max. 25 km/h or 6.9 m/s) • Note: It is strongly recommended to adjust the wind speed during the installation of the system to 50% of the maximum permitted speed and to check the behavior of the system if there is wind. • No rain (when the sail is extended) if inclination < 15° • No snow (when the sail is extended) • No operation at temperatures < 5°C • No use in wet areas such as swimming pools etc. (230V drive)
	<p>The freely installed Furling core must not be applied to external forces.</p> <p><u>These are, for example:</u></p> <ul style="list-style-type: none"> • Exposure to persons/ animals (hanging, sitting, running) • Exposure to objects (buildings, plants, laundry, supporting/ hanging/ pulling) • Exposure to water and hail/ snow (which accumulates in the sail) • Wind loads above the permissible wind speed
	<p>Ropes, ball bearing blocks, entire ropes of the sailing guide and the sail itself must not be obstructed/ inhibited by objects/ persons in their free movement.</p>
	<p>Noises / vibrations from the sun sail system are technically unavoidable and can be transferred to parts of the building and possibly spread / amplify there.</p> <p><u>Noise when furling or unfurling the sail</u></p> <p>Motor noise from the winding axis (motor / gearbox under load)</p> <p>Line winding noises on the spool disc (line skipping)</p> <p>Noises from the line routing (deflection blocks, tensioning technology, lines, sails)</p>

	<p><u>Wind noise (when the sail is furled and/or unfurled)</u> Wind noise (whistle and/or hum) from stretched lines/guide wires Wind noise on masts, consoles, winding axles, sails Noises from the line routing (deflection blocks, tensioning technology, lines, sails)</p> <p>Noise can be partially reduced by damping elements (individual examination/test required). Noises from movement sequences and from the influence of wind are technically unavoidable and do not represent a defect in the product.</p>
--	--

2.3 Delivery

	<p>SunFurl® RES sun sail systems are planned individually. The scope of delivery is therefore determined individually (see parts list on the offer and/or drawing).</p> <p><u>Typical components are:</u></p> <ul style="list-style-type: none"> • Winding core including end bearings and internal 230V AC drive • Wall plates (for fixing the winding core and for the line guide) • Poles D100 / stainless steel and aluminium • Ground sockets, ground flanges, screw foundations, wall flanges for pole mounting • Line storage (with internal gas spring tensioning mechanism) • Line routing system (blocks, lines, ...) • Custom made sails • Weather control (wind/rain monitor) incl. radio control unit • Special tools, screw lock, spare screws • Assembly instructions / operating instructions / planning sketch (individual drawing)
--	---





2.3.1 Furling core incl. Mounting elements

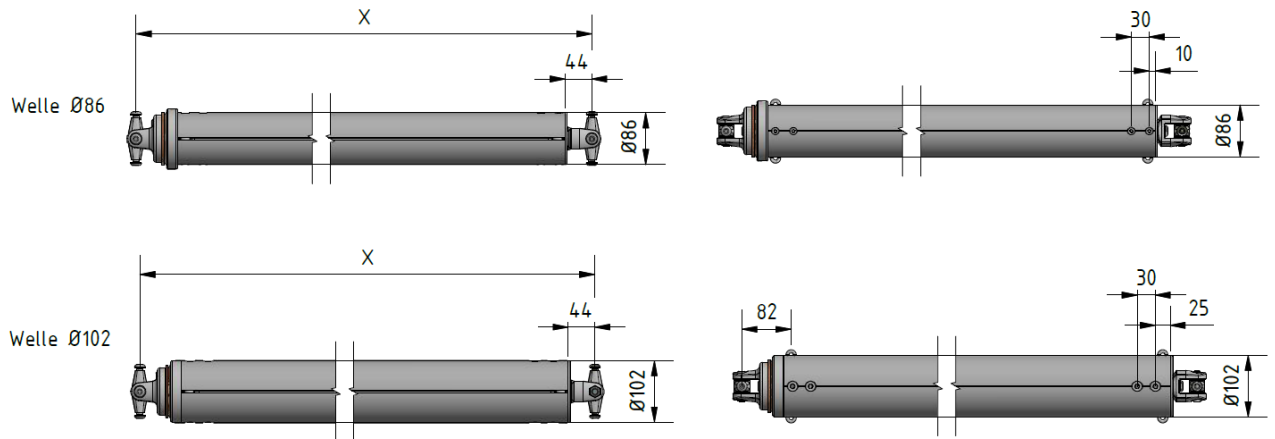



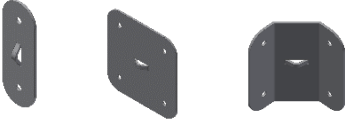

	<p><u>Furling cores are available in standard lengths</u></p> <p>D86 shaft in 3 m / 1.5 m pitch D102 Shaft in 4 m / 2 m pitch</p> <p><u>Note:</u> With D86 shaft, total lengths in the range of 350 mm above the pitch dimension of 3 m should be avoided as far as possible, as these cannot be constructed with standard profiles (connectors require 250mm, end bearings require 100mm).</p> <p>With D102 shaft, total lengths in the range of 450 mm above the pitch dimension of 4 m should be avoided as far as possible, as these cannot be constructed with standard profiles (connectors require 295 mm, end bearings require 155 mm).</p> <p><u>Furling core consisting of:</u></p> <ul style="list-style-type: none"> • Aluminum profile tube (D86 or D102) • 1-3 Aluminum connector incl. mounting material (screws + screwdriver) • Motor head (incl. 230 V AC drive) mounted on the initial profile • Extension profile (connector of holes on both sides) • End profile (connector holes one-sided) • End bearing (mounted to assembly size at the installation site after the final profile has been lengthened)
--	--



Furling core D86 und D102



2.3.2 Standard mounting elements

	<p>Wall plate Furling core</p> <p>W x H: 230 x 230 mm</p> <p>Bore spacing: 150 mm Margin spacing: 40 mm Material: stainless steel, surface ground + electro polished (semi-gloss shiny)</p>
	<p>Wall plate Furling core (parallel to a wall)</p> <p>W x H: 230 x 80 mm</p> <p>Bore spacing: 150 mm Margin spacing: 40 mm Material: stainless steel, surface ground + electropolished (semi-gloss shiny)</p>
	<p>Wall plates with eyelet for Rope steering</p> <p>W x H: 230 x 230 mm W x H: 230 x 80 mm</p> <p>Bore spacing: 150 mm Margin spacing: 40 mm Material: stainless steel, surface ground + electropolished (semi-gloss shiny)</p>
	<p>Masts of \varnothing 100 mm and \varnothing 86mm</p> <p>Material: Aluminum, surface anodized (natural)</p> <p>Connecting parts to masts via clamping parts, stainless steel casting</p> <p>Masts are available in lengths up to 5 m in 0.25 m increments</p> <ul style="list-style-type: none"> • Profile mast with grooves • Stiffening for profile mast (various lengths available) • Clamping tab for mounting axis (required in pairs) • Clamp eye for deflection leash (fit for connection shackle and snap hook) • Lid for profile mast

	<p>Mast foundations</p> <ul style="list-style-type: none"> • Ground sleeve (for concrete foundation) • Wall flange (for attachment to a parapet / wall (required in pairs)) • Floor flange with spike tube (for attachment to floor / foundation plate) • Screw foundation
	<p>rope storage For aluminum profile poles Ø 100 mm and Ø 86 mm Freely rotatable guide rollers / internal gas springs</p> <p>The length compensation element. A free insertion depth of 2,175 mm into the mast is required.</p>
	<p>Ball bearing block with swivel for 5 mm rope WL2,0 kN / BL4,0 kN</p>
	<p>rope / Dyneema / x 5 mm BL 7,5 kN</p> <p>Note: The leash is a wear part that must be checked regularly and replaced in case of wear and tear. The leash should be replaced after 3 years at the latest due to UV damage.</p>
	<p>Height adjustment of sail extension</p> <ul style="list-style-type: none"> • Manual via tackle • Manual via winch • Electrically via add-on unit with tubular motor (observe separate installation and operating instructions) Only for masts Ø 100 mm
	<p>Wind, rain, light, temperature sensor Incl. remote control</p> <p>Standard: Elsner / Solexa I Optional: Elsner / Solexa II Optional: Becker / BR-SC861</p>
	<p>Mounting set (standard scope of delivery) for assembly and maintenance work</p> <ul style="list-style-type: none"> • Replacement screws • Trimming handle for rope tension • Operating / Mounting instructions SunFurl® RE • Operating instructions for third-party components (drive, weather control, main switch)

	Further components / options can be found in the Individual Customer Planning Design.
	<p>Special surfaces (optional)</p> <ul style="list-style-type: none">• All components (wall panels, masts, winding axis) powder-coated in the color of your choice

3 Safety

3.1 General safety

	Observe all instructions and guidelines in this documentation, including the assembly and operating instructions from Becker for the installed tubular motor, as well as the installation and setting instructions for the shading control from Elsner Elektronik / Solexa 230VAC (or optionally the control from Becker BR-SC861). In addition, accident prevention regulations and instructions for the area of application must be observed.
--	---

3.1.1 Signal words and warning symbols used

	<p>Attention! This symbol indicates an imminent or potential danger to the life and health of persons. Failure to follow these instructions can have serious effects on health or life-threatening injuries. Significant damage to persons and equipment can occur as a result.</p>
	<p>Attention! Dangerous electrical voltage - indicates a risk of electric shock and warns of imminent danger to the life and health of persons in contact with the hazard. Significant damage to persons and equipment can occur as a result.</p>
	<p>Attention! Danger of crushing - indicates a risk of mechanical injury to body parts and warns of imminent danger to the life and health of persons in contact with the hazard.</p>
	<p>Attention! Expertise required - the work may only be carried out by trained persons with appropriate specialist knowledge. In case of ambiguity a specialist of the BARTELS GmbH must be consulted!</p>
	<p>Important informations: Information that must be observed during installation and use of the product to avoid process interruptions or malfunctions.</p>
	<p>Hint: Gives the user the information needed to reach a task / target directly and without problems.</p>
	<p>Further detailed information: Indicates to the user that more information is available on this topic (e.g., separate instruction manuals of built-in components or other guidance aids / documentation)</p>

3.1.2 Guidelines and standards

	The guidelines and standards that are taken into account during development and assembly can be found in the Declaration of Conformity (section 13).
--	--

3.2 Safety instructions for the operator

3.2.1 Guidelines and standards

	<ul style="list-style-type: none">• For electrical installations, the EMC Directive (2014/30 / EU) and the Low Voltage Directives (2014/35 / EU) must be observed• Protection and testing ordinance (DIN EN 60204-1 of DIN VDE 0113) for continuous connection of the protective conductor system• The electrical installation may only be carried out by a specialist! Knowledge of the relevant VDE regulations, state regulations and accident prevention regulations with experience through a timely professional activity in the relevant field of electrical engineering and electronics is required.• During installation, the installation instructions (EN 60335-1: 2014 and EN 60335-1: 97: 2015) as well as the minimum distances against the reaching of hazardous areas with upper and lower limbs must be observed (DIN EN ISO 13857: 2008)
---	---

3.2.2 Occupational safety

	<ul style="list-style-type: none">• Wear protective equipment (safety shoes, gloves, safety glasses, safety helmet)• Always carry out installation work for two (partly heavy weight of components or for protection when working on ladders or lifting platforms)• When installing large / bulky / heavy components (winding core) it is essential to secure the component (against falling down) with a leash. On the winding core, the eyelets of the sail attachment can be used on both sides.• Electrical installations may only be carried out by a specialist: Knowledge of the relevant VDE regulations, state regulations and accident prevention regulations with experience through a timely professional activity in the relevant field of electrical engineering and electronics is required. Completion of a recognized electrotechnical specialist training for the intended, activities with a comparable electrical qualification in the area of responsibility to be performed.
---	---

3.2.3 Technical condition of the product





	<p>The operator of the awning system is responsible for the regular maintenance of the entire system!</p> <p>Details siehe Wartungsplan im section Fehler! Verweisquelle konnte nicht gefunden werden.</p> <p>Particular attention should be paid to the condition of the attachment points of the hub and the condition of the lines!</p>
---	---







3.3 Safety instructions for the operating personnel



3.3.1 Personnel to be assigned and qualification

	<p>The operation of the rolling system may only be carried out by instructed persons! Children under the age of 14 and mentally handicapped persons are only allowed to operate the rolling system under the supervision of a trained person.</p>
---	---

3.3.2 Danger spots and possible accident hazards



	<p>Danger due to overloading the system</p> <p>The winding core must not be overloaded in order to exclude consequential damage! The operator and the operating personnel are obliged to protect the system from damaging influences!</p> <ul style="list-style-type: none"> • Wind (a wind monitor must be provided to retract the sail when the wind picks up) <ul style="list-style-type: none"> ○ Up to 9m D86 axis > 6 Bft (max. 45 km/h or 12.5 m/s) ○ Up to 10m D102 axis > 6 Bft (max. 45 km/h resp. 12,5 m/s) ○ Up to 12m D102 axis > 5 Bft (max. 35 km/h resp. 10,7 m/s) ○ Up to 14m D102 axis > 4 Bft (max. 25 km/h resp. 6,9 m/s) • Rain/ Hail / Snow (a moisture monitor must be provided to retract the sail in case of rain, hail or snow) • Icing (a temperature sensor must be provided to deactivate the sail if the temperature falls below 5°C when closed) • Objects (branches, parts of buildings, etc.) • People (sitting, hanging, etc.)
	<p>Danger from winding core</p> <p>In the event of an overload due to external forces (as mentioned above), the winding core can be damaged.</p> <ul style="list-style-type: none"> • Severe bending/breaking • Tear anchors out of the wall • Bending masts / tearing anchorages out of the ground <p>The danger lies in the weight of the winding core, which can cause personal injury and damage to property!</p>
	<p>Danger from height adjustment</p> <p>Height adjustments may only be used up to a maximum sail extension of 6.0 m (with a maximum stroke of the line storage of 7.5 m)! Applies to manual and electric variants.</p> <p>The sail must be able to roll in completely, even when the height adjustment is in the lowered position (check during assembly, determine and limit the max. permitted lowered position)</p> <p>The danger is that when the height adjustment is in the lowered position, there is not enough line in the line store to furl the sail completely. This can lead to overloading of the winding axis (drive and mechanics).</p>
	<p>Danger from lines and sails</p> <p>Due to the gas springs of the line storage, the pull lines are constantly under a high tension of up to 750 N.</p> <p>If the line is severed / or the breaking load of the line is reached (full breaking load with a new line or reduced breaking load with an aged/worn line), it can tear. As a result, the line is suddenly pulled into the mast due to the spring tension (together with ball bearing blocks attached to it). In addition, the pull-out side of the sail falls down onto</p>

		objects and people underneath! (The sail remains attached to the winding core)
 		<p>Gas spring hazard</p> <p>Two strong gas pressure springs are installed in each line store. The gas springs are under high pressure and must not be damaged, opened or overheated!</p> <p>The piston rods of the gas springs can buckle under load! The gas springs / line accumulator may only be subjected to a force within one mast / enveloping tube (the three green centering rings must all three be intact). The line store may only be removed from the mast/sheathing tube without any pre-tensioning force.</p> <p>ATTENTION: All work in the area of the gas springs / on the line storage may only be carried out by trained personnel!</p>
		<p>Danger of crushing on rollers / spools of the rope guidance.</p> <p>Never reach into the danger zone of moving parts with limbs during operation!</p> <p>ATTENTION: All moving parts must be mounted out of reach of persons! At least 2.7 m above the floor. At least 1.2 m below parapets (from which moving parts can be accessed from above).</p>
		<p>Danger of crushing on moving parts of the winding core</p> <p>Never intervene in the danger zone of moving parts with limbs during operation!</p>
		<p>Danger of pulling hair into the area of moving parts</p> <p>Never intervene during operation in the danger zone of moving parts with hair!</p> <ul style="list-style-type: none"> • Blocks • reel disks • ropes • furling axis
		<p>Risk of falling components or entire assemblies due to inadequate fastening / securing (winding core, fastening elements, etc.)</p> <ul style="list-style-type: none"> • Fixing elements (threaded rods, expansion anchors, etc.) must be carefully selected according to the substrate! • Foundations are sufficiently heavy / stable! • Mast inserts must always be fixed using the locking screw! • Fixing screws on ground sleeves or screw foundations must be tightened and secured • All threads of screw connections must be provided with a medium-strength thread lock! (Screw lock included) • All fastening screws must be tightened and checked regularly

		<p>Risk of burns</p> <p>Risk of skin burns from metal surfaces heated by the sun</p> <p>Danger of skin burns due to heating of the drive within the winding core during continuous operation or overload. The winding core can have increased temperatures in the area of the drive. The operating instructions for the tubular motor must be observed!</p>
		<p>Only carry out maintenance work when the safety switch is in the zero position!</p> <p>If this is not observed, the sensors can roll the sail in or out at any time (depending on the programming of the wind/sun/rain sensor).</p> <p>Accidental furling or unfurling of the sail can result in personal injury and/or damage to property!</p>

3.4 Specific components (Safety instructions)

3.4.1 Safety devices / main switch











	 <p>For example Type: Eaton T0-2-1/I1/SVB</p>	<p>Safety switch</p> <p>During installation, a safety switch must be provided to completely disconnect the drive system from the power supply. The safety switch must be installed by a qualified electrician at a suitable point near the rolling system. The switch must be able to be secured against unauthorized / unintentional actuation.</p> <p>The switch is not included. A suitable switch must be selected and installed by the installer.</p> <p>During assembly/disassembly and maintenance, the safety switch must be set to the zero position and secured against being switched on unintentionally (lock)!</p> <p>In the event of a longer absence (e.g. vacation), it is recommended to set the safety switch to the zero position when the sun sail is rolled up in order to avoid unwanted operation (by a sensor control and untrained persons).</p>
---	---	--



3.4.2 Safety and warning labels

	<ul style="list-style-type: none"> • Nameplate with information on the installed drive type / power consumption / serial number / etc.
---	---

3.5 Specific energy systems (Safety instructions)

3.5.1 Electric / Gas spring

 		<p>Drive</p> <p>A 230V AC tubular motor is installed in the winding core. The drive drives the winding core. Freely adjustable limit switches are included in the drive. The limit switches must be set to limit the movement (rolled in and out of the sun sail)!</p> <p>ATTENTION: The electronics (drive, safety switch, weather control) must be installed and commissioned by a qualified electrician!</p> <p>Details on the installed tubular motor in section 12.4</p>
 		<p>Gas Springs</p> <p>Two strong gas pressure springs are installed in the line storage for masts with a diameter of 100 mm, and one strong gas pressure spring for masts with a diameter of 86 mm. The gas springs are under high pressure and must not be damaged, opened or overheated!</p> <p>The piston rods of the gas springs can buckle under load! The gas springs / the line accumulator may only be subjected to a force within a mast / enveloping tube (the three green centering rings must all be intact and pushed into the mast). The line store may only be removed from the mast/sheathing tube without any pre-tensioning force.</p> <p>ATTENTION: All work in the area of the gas springs / on the line storage may only be carried out by trained personnel!</p>
 		<p>Weather sensors / radio control</p> <p>Weather sensors (wind, rain, light, temperature) must be used to protect against damage caused by wind and rain. Included in the standard scope of delivery.</p> <p>Either the tubular motor is integrated as a participant in an existing home control system, or the weather sensors supplied by BARTELS are used.</p> <p>The motor voltage is routed through the sensor unit and from there via a relay to the tubular motor. When working on the sensor unit, it must first be switched off!</p> <p>The electronics must be installed and commissioned by a qualified electrician!</p> <p>The instructions in the separate operating instructions for the weather sensors must be observed! Please refer section 12.</p>
		<p>Protective conductor connection in continuous design</p> <p>The wall plates have a M5 threaded hole for attaching a protective conductor. It must be connected in order to keep all metallic surfaces of the rolling system (including all related fasteners, masts, line guide elements) de-energized in the</p>



		<p>event of a fault. In exposed locations, the connection to the lightning protection system must also be observed.</p> <p>In exposed locations, the connection of the masts to the lightning protection system must also be taken into account.</p>
	 <p>(picture = example)</p>	<p>Fault current circuit breaker</p> <p>The awning roll system (tubular motor, optional sensor electronics, cabling) must be connected in a circuit of the house electrics via a FI (residual current circuit breaker)</p>

3.6 specific lifecycle of the product (Safety instructions)

3.6.1 Transport

	<ul style="list-style-type: none"> • Suitable safety equipment must be worn for transport and unpacking! (Safety shoes, gloves, helmet, goggles) • Hard, can fall on your feet • Sharp-edged, rough • screws, nails • Never carry heavy parts alone!
---	---

3.6.2 Installation/ Assembly

 	<ul style="list-style-type: none"> • Installation must be carried out by persons with sufficient expertise in mounting heavy objects on buildings. • Installation work must be carried out by at least two persons • Hard, can fall on your feet • Danger of falling when working on ladders / platforms / lifting platforms • All screws connections must be secured with Loctite 243 screw protection
--	---

3.6.3 Service and maintenance

	<ul style="list-style-type: none"> • Service and maintenance must be performed by a trained person • Suitable safety equipment must be worn for maintenance! (Gloves, goggles) • A maintenance interval of max. one year is to be kept • Prior to any maintenance, the safety switch must be set to zero position to prevent unintentional starting of the winding core • Maintenance details are described in section 0.
---	--

3.6.4 Dissassembly and Disposal

	<ul style="list-style-type: none"> • Set safety switch to zero position • Disconnect the electronics from the mains by a qualified electrician • Disassembly must be carried out by persons with sufficient expertise in dismantling heavy objects on buildings. • Appropriate safety equipment must be worn for disassembly and removal! (Safety shoes, gloves, helmet, goggles) • Installation work must be carried out by at least two persons • Hard, can fall on your feet • Never carry heavy parts alone
---	--

3.7 Safety instructions for materials and supplies

3.7.1 Materials used and surface coatings

	<ul style="list-style-type: none">• stainless steel• aluminum• POM / PETG plastic• Eloxal as decorative layer• Optional powder coating as decorative layer
--	--

3.7.2 Oils / Greases

	<ul style="list-style-type: none">• Lubricant KLÜBER Polylub GA 352P (engine head bearing)• Lubricant WÜRTH HHS 2000 (reduction of cold welding tendency in threads)• Threadlocker Loctite 243 (5ml tube included)
--	---

4 Product description

4.1 Name of the product

	<p>Awning System SunFurl® RES</p> <ul style="list-style-type: none"> • Electrically operated winding axis (230V / AC) • Tension and storage of the sail pull lines via gas springs in masts • Controlled via sensor control (automatic or manual operation). To avoid overloading, automatic operation with weather control is mandatory in order to retract the sun sail when the wind picks up and/or it rains.
--	---

4.2 Controls

	<p>The operation of the rolling mechanism for rolling in and out of the awning can be realized by different ways. Three typical ways are shown below.</p>	
		<p>Radio remote control coupled with a sensor unit (Automatic and manual operation possible)</p> <p>In automatic mode, the sail is automatically rolled up according to the sensor configuration in the case of refreshing wind or heavy rain.</p>
	<p>Any home control with free output for controlling an additional subscriber (230V / AC tubular motor).</p>	<p>Operation via existing home electronics / home control at the installation site.</p> <p>The automatic mode must be configured in such a way that the sail is rolled up automatically in the case of refreshing wind / downpour / snow.</p>

4.3 Overview of the product and its components and connections

The core elements of the **SunFurl® RES** sun sail system is the winding core with bearing elements on both sides and integrated tubular motor as well as one or two line storage and tensioning systems (gas spring) integrated in masts.

SunFurl® RES awning systems are planned individually. The individual construction of the system can be found in the respective planning documents. The illustrations below show typical installation variants.

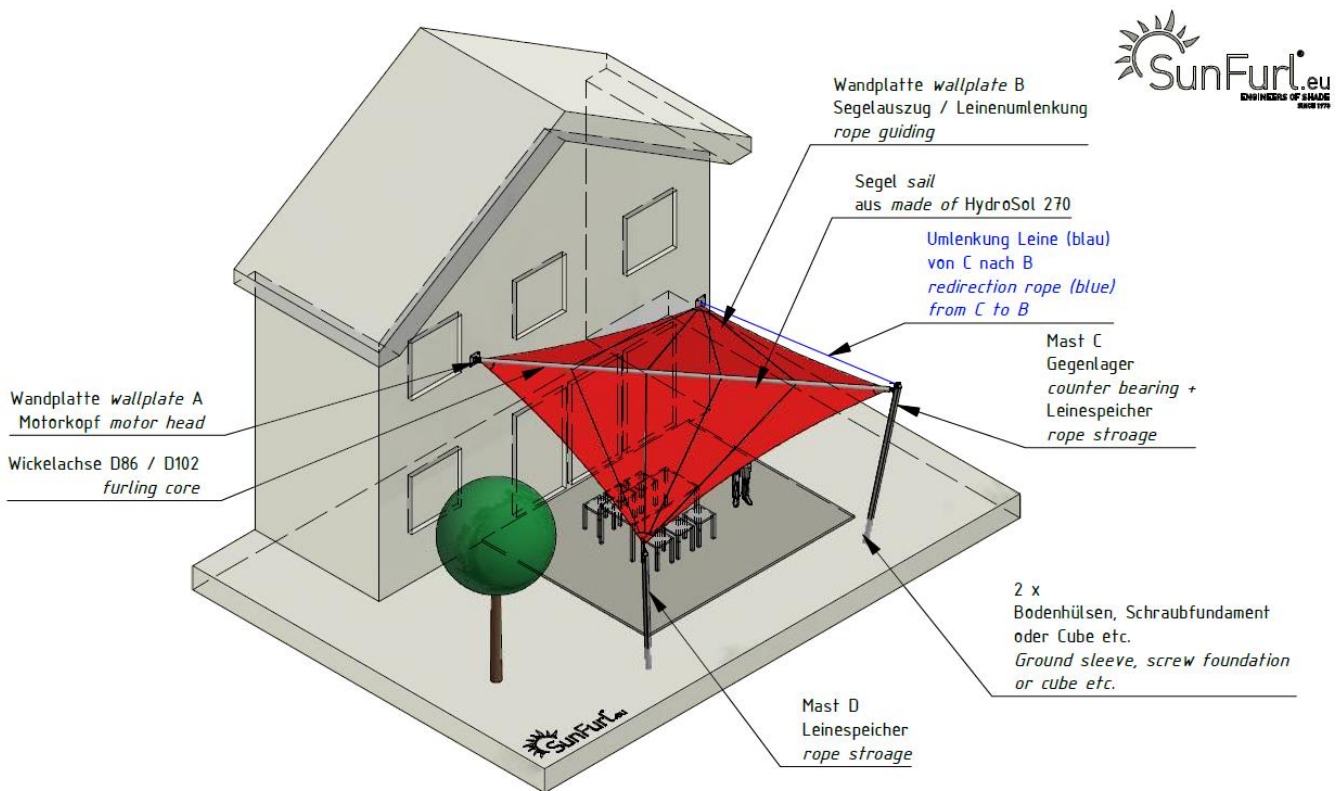

Typ: SF-RES-A1

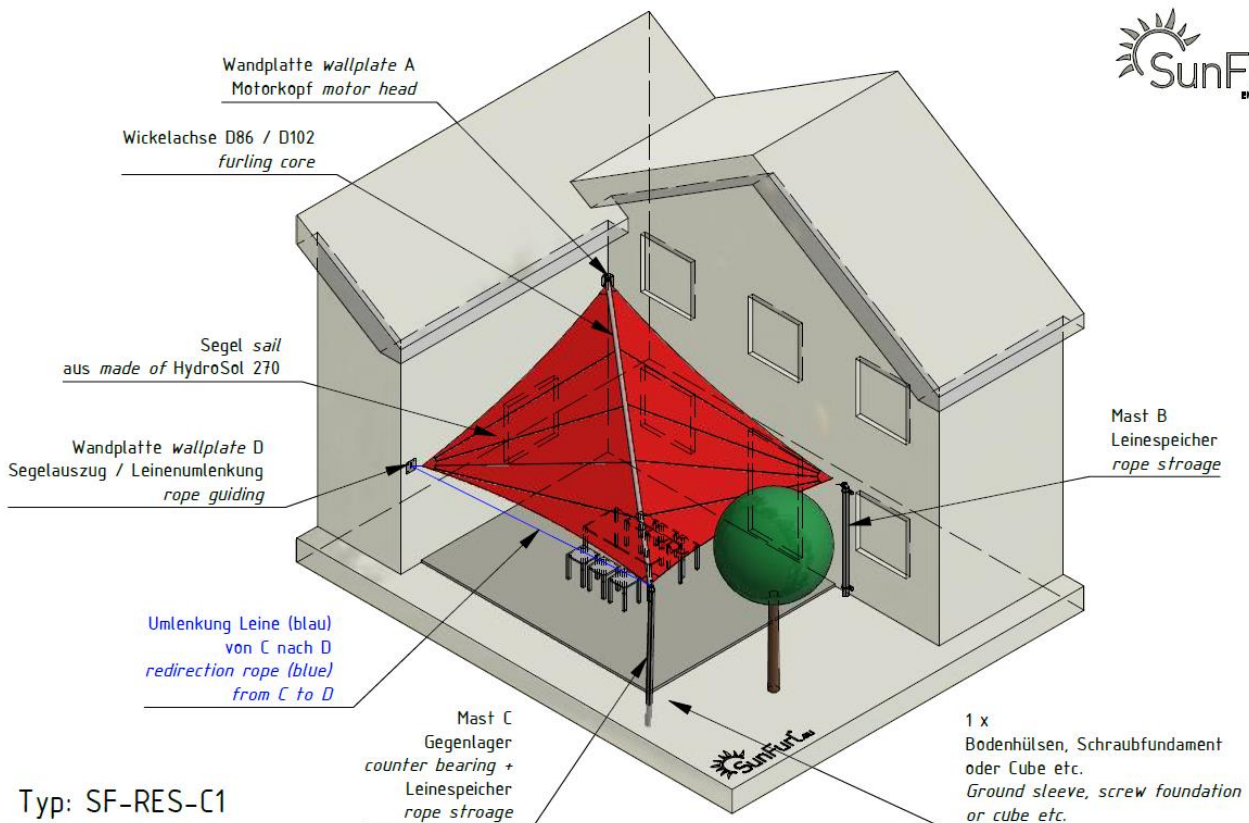
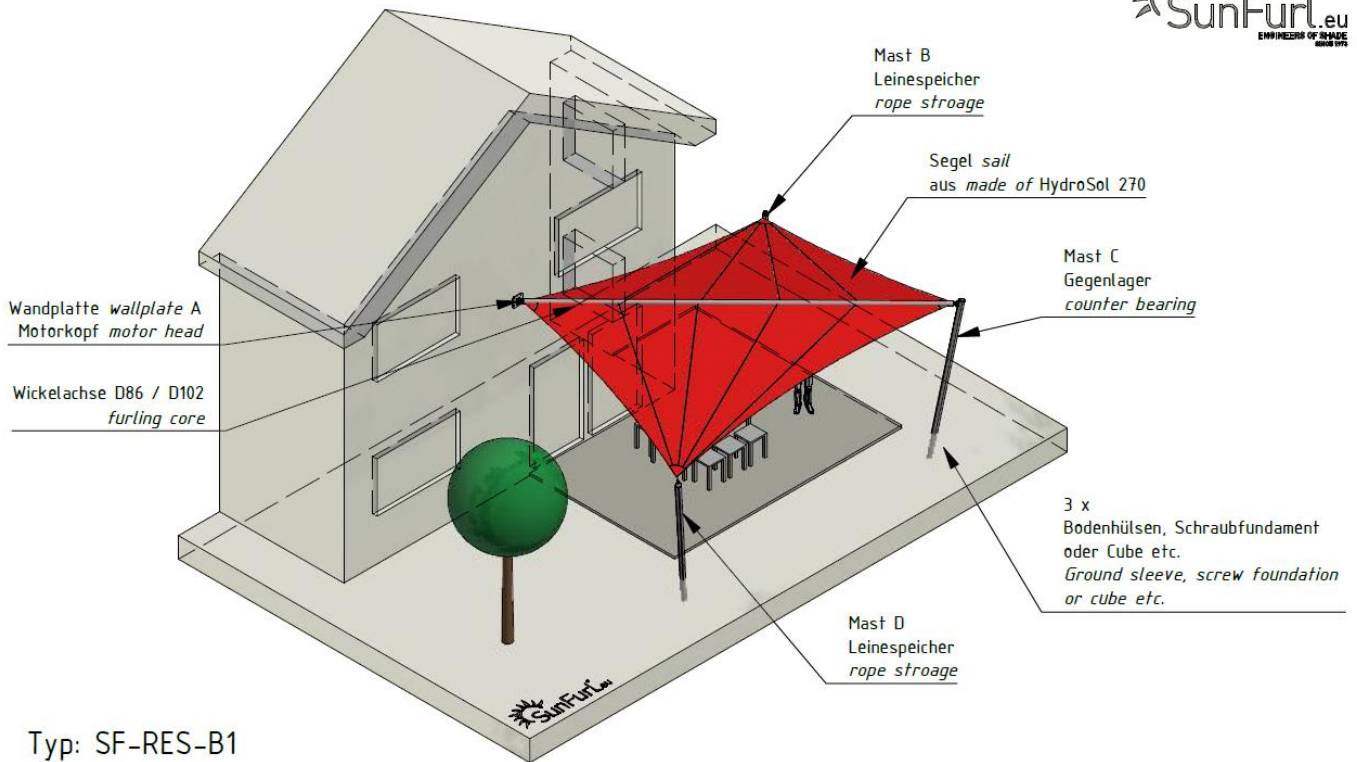

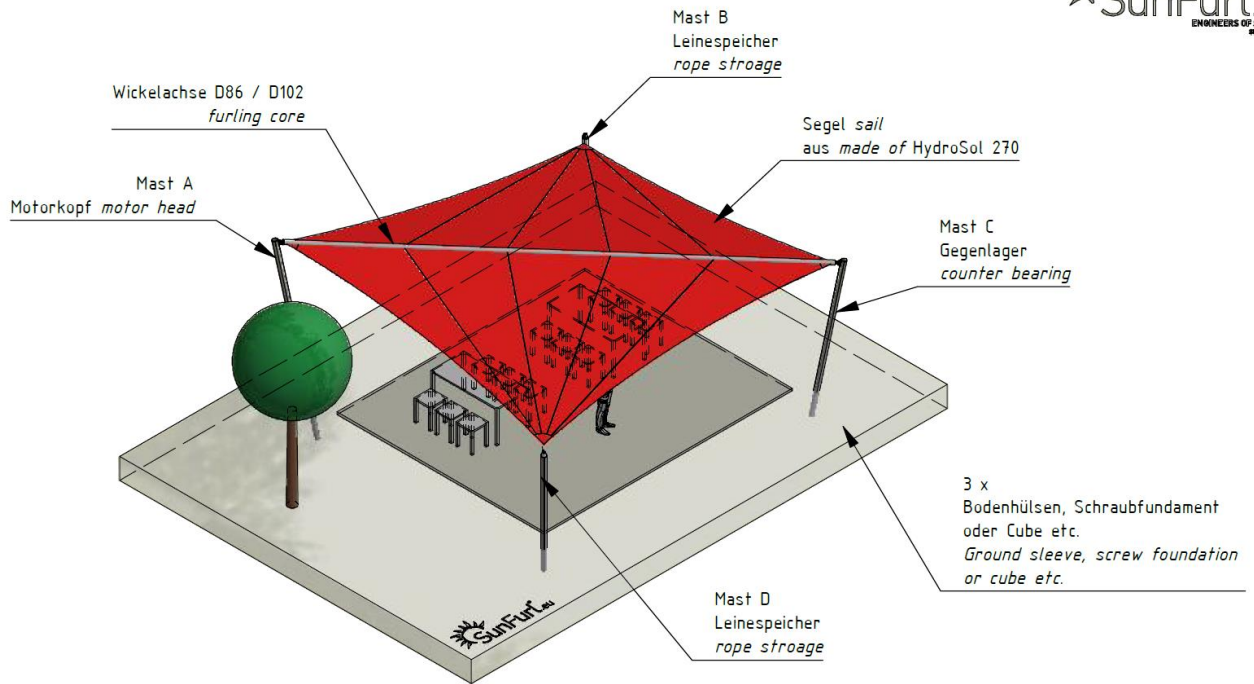

Typ: SF-RES-D1

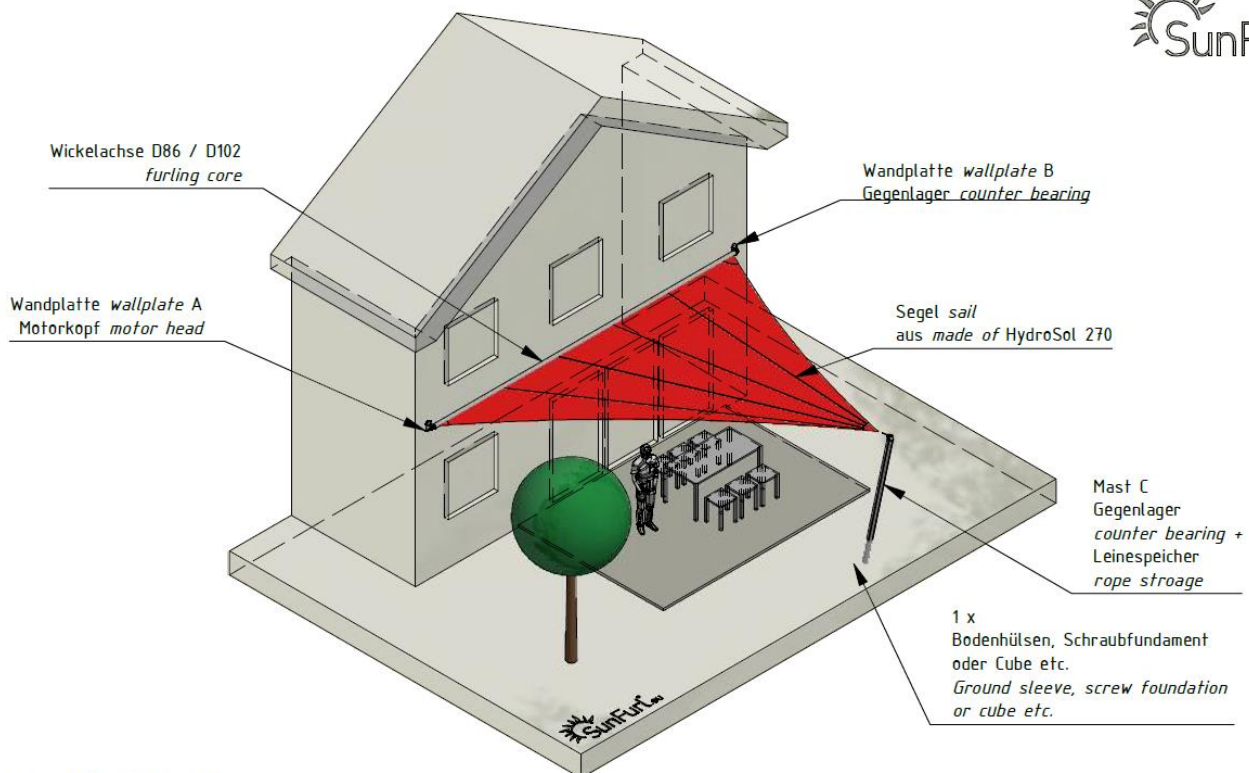

Typ: SF-RES-E1

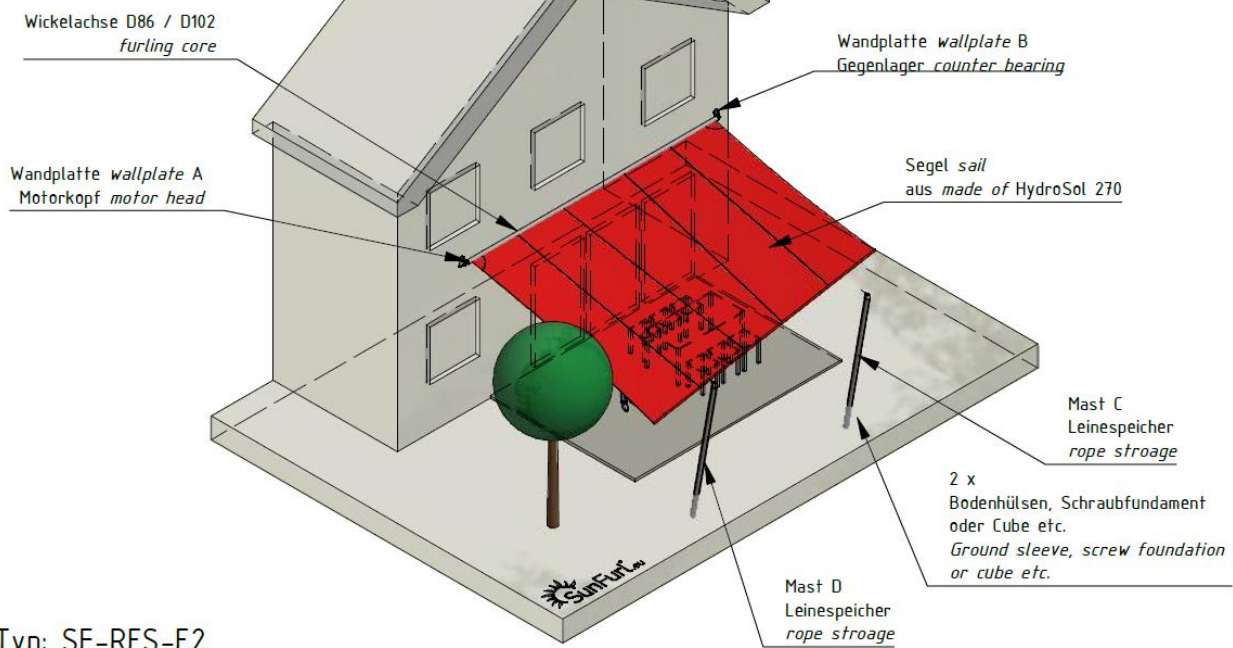





Typ: SF-RES-E2

5 Installation

5.1 Unpacking / transporting of the product

	The safety instructions from section 0 must be observed
	If possible, transport the system in the shipping container to the installation site to prevent damage to the hub / wall plates / etc.

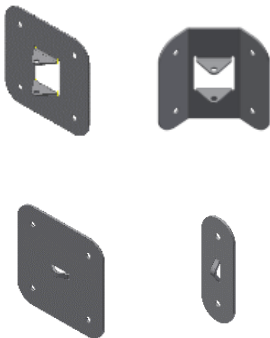
5.2 Assemble the product

	The safety instructions from section 0 must be observed.	
	When mounting on walls, they must be sufficiently stable and suitable screws and dowels must be used. If necessary, obtain advice on suitable screws / dowels in a specialist market. See also further documents and fastener recommendations in section 12.2 .	
		<p>Mounting of wall plates</p> <p>ATTENTION: The motor side of the winding core must be mounted above the counter bearing to prevent moisture from accumulating in the area of the drive! The cable connection from the motor head must point upwards when installed! Lay the tubular motor connection cable with the cable bend down to the building wall in a U-shape so that rainwater drips off the cable bend and cannot flow into the tubular motor housing!</p> <p>Always replace the motor connection cable and seal with the original cable/original seal.</p> <p>Notes For fasteners see section 12.2</p>
		<p>Install / set base masts</p> <ul style="list-style-type: none"> • Concrete in the ground sleeve. Foundation dimension approx. 750x750x750 mm. With large sail areas and/or soft bottoms, the foundation should be larger. It must always be concreted in "grown soil", not in rubble or in sand heaps! Floor class greater than 3 required. • Screw in the screw foundation. e.g. Krinner ground screws KSF E140x1300-E76-100 with eccentric set E100) • Clamping flanges on the wall/ parapet/ facade • Floor flanges on floor, ceiling <p>Notes Foundation fittings see section. 12.2.5</p>

RES
Mast Motorkopf
oder
Mast Gegenlager

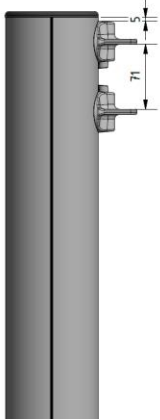

RES
Mast Motorkopf
+ Leinenspeicher

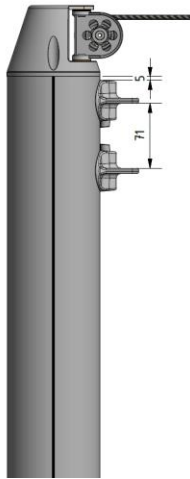

RES
Mast Leinenspeicher

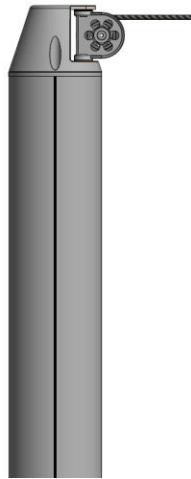

Assemble masts

Adjust and align masts in foundations
Mount connections (clamping parts) and end caps
Insert rope storage

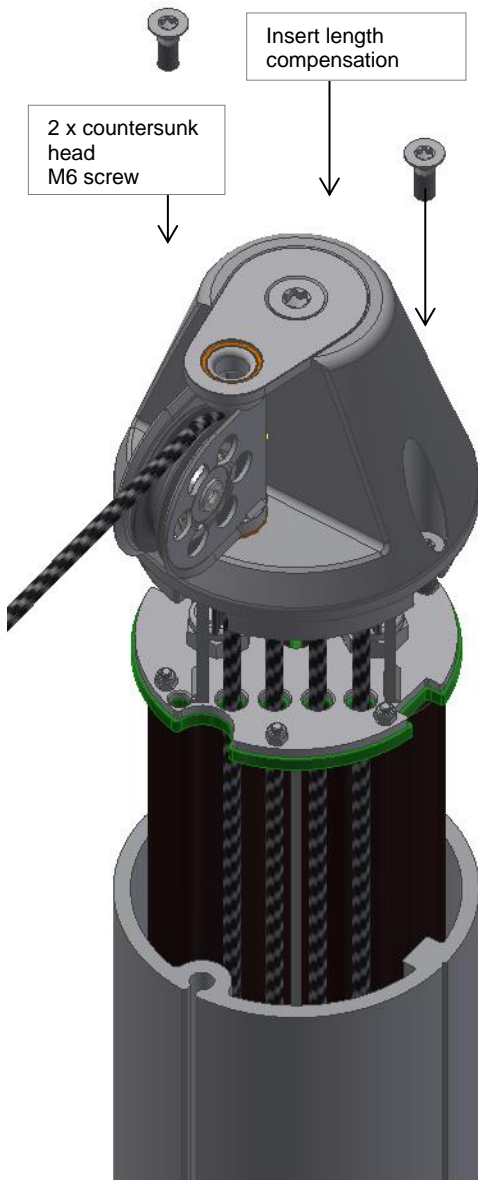

Mounting the line storage

The line storage is inserted into a mast from above and secured from above using two M6 countersunk screws.

ATTENTION:

When pushing in, do not damage the surface of the piston rods and the green sliding elements!
Make sure that all lines run freely (keep the line on the pulley slightly under tension when pushing in).

ATTENTION: Danger of crushing hand / fingers when pushing the tubes together.

ATTENTION: Line storage is heavy / pay attention to centre of gravity when pushing in. Must be pushed in from above from a safe position.

ATTENTION: Tighten 2 x M6 countersunk screws from above.

5.3 Mast securing

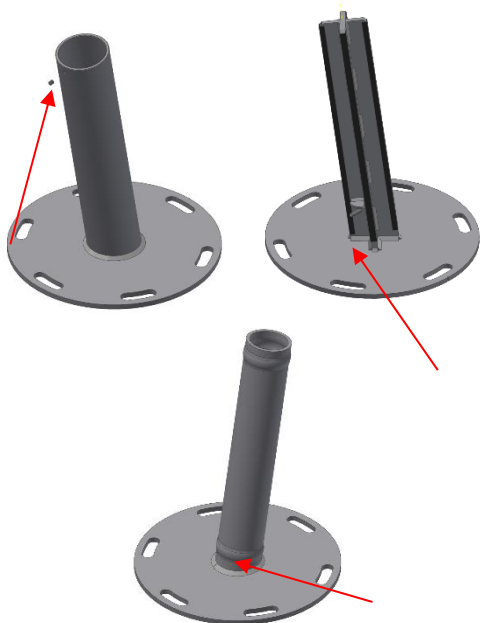

Anti-lift flange feet

Masts that are fastened with a spike flange foot or in a quiver flange foot must be secured against being pulled out!

- In the case of quiver flanges, there is a thread in the quiver tube. Adjust the mast and secure it in the desired position with a screw.
- In the case of mandrel flanges, a thread must be provided on site in the mast tube. Attach the mast and insert the thread according to the drawing. The screw must be placed below the bar (cross mandrel) or below the flare (tubular mandrel).



Mount the winding core (elements)

Depending on the length of the winding core, it consists of 2, 3 or 4 parts (1 to 3 connectors).



ATTENTION:

- Use only the screws included in the scope of delivery
- Use medium-strength Loctite screw lock to secure
- Mount sliding foils (observe enclosed instructions)
- Mount intermediate foils
- Only use the supplied Torx T-handle screwdriver (do not use fast-turning screw aids)
- Immediately replace screws damaged during assembly (spare screws included in the scope of delivery)

Proceed:

- Prepare connectors (see connector instructions)
- Push the connector into the first profile + loosely insert the screws through the profile
- Mount the intermediate foil on the face of the axle
- Slide the second profile onto the connector + loosely insert the screws
- Position all screws and tighten slightly
- Gradually tighten all screws
- After a few turns of the winding core (before the sails are pulled in), tighten the screws again!



Notice:
It is imperative that the following parts are fitted:

- Slides (1)
 - Bushings (2)
 - sealing washer (3)
- Otherwise noise could be generated or the winding axis could be damaged

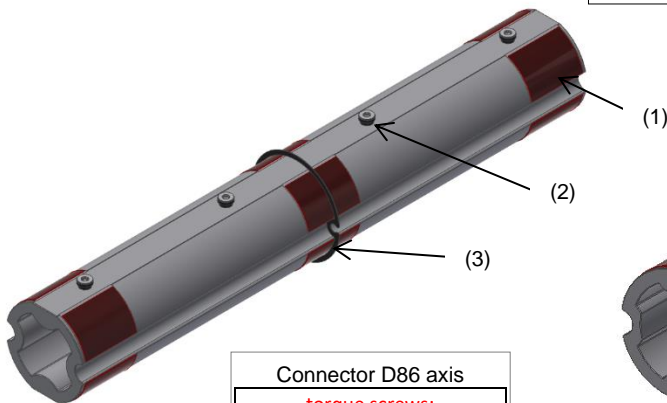

Connector D86 axis

torque screws:
9Nm



Connector D102 axis

torque screws:
12Nm

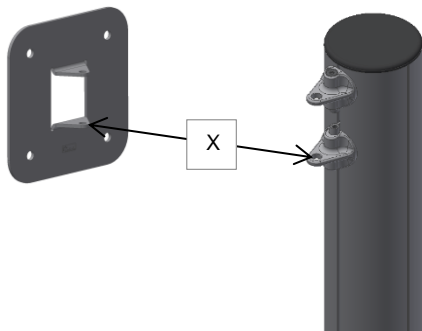

Measuring the winding core length

The wall mounts must be installed.
Masts must be installed and aligned (height and angle).

Use a metal tape measure to measure the center distance from the lower hole in the motor head mount (fork) to the lower hole in the counter bearing mount (fork) (dimension X).



Cutting the winding core to length

CAUTION: Risk of injury from the sharp-edged cut surface and/or chips (wear safety equipment!)

ATTENTION: Only the end piece (on the non-drilled side) may be shortened!

ATTENTION: Observe the safety regulations for using the miter saw. To prevent the cut piece from jamming, the minimum section must be at least 30mm! Always carry out the cutting process with two people. If sufficient profile is available, make a test cut in the waste piece beforehand.

Proceed:

- Mount profile elements on the floor
- Determine the distance between the fastening points on the wall plate and support (dimension X)
- Counter bearing fully pushed in
- **The dimension between the attachment points (X) minus 44mm (shaft D102) or 51mm (shaft D86) corresponds to the dimension from the motor-side cross piece to the saw mark (see drawing below)**
- Carefully cut off the profile tube at the saw mark with a chop saw
- Remove sawdust from the cutting edge on the profile and deburr it

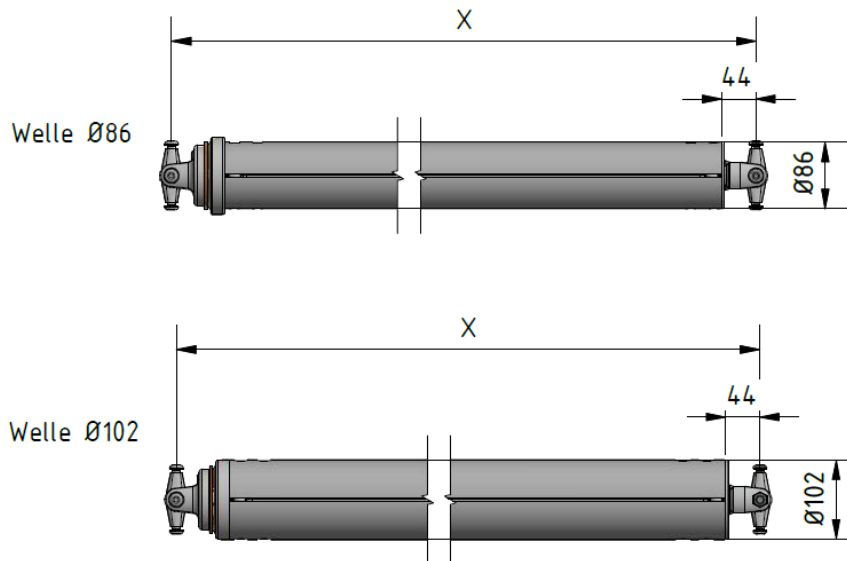



Welle D86: Thread M6

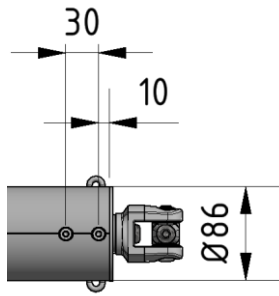

Welle D102: Thread M8

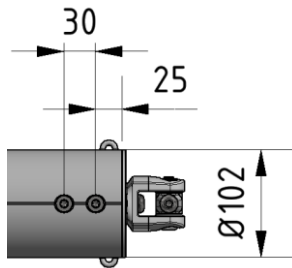

Insert holes for counter bearing and mount counter bearing

ATTENTION:

Hole pattern different for D86 and D102 shaft
Holes different for D86 and D102 shaft

ATTENTION:

Drillings must be made in the area of the web (notch on the outside of the profile tube)

Proceed:

- Drill the holes and countersinks for the counter bearing on both sides according to the adjacent sketch (on the notch on the profile tube)
- Drilling + countersinking
- Remove chips from the machining area on the profile and deburr
- Push in the counter bearing (first push the trimming hooks into the grooves)
- Fastening of the counter bearing with 4 x Torx countersunk screws



M10x16 Screws

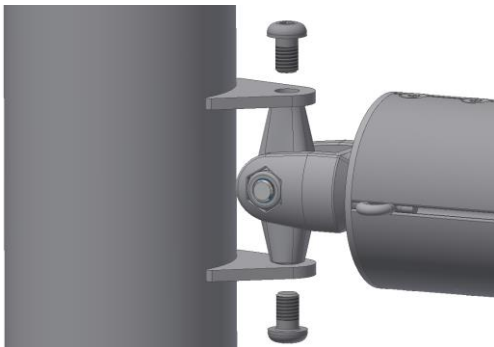

M10x16 Screws

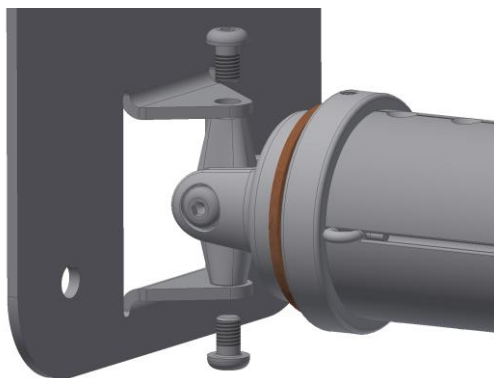

Install winding core between house wall and masts

ATTENTION:

Secure the winding core against falling with a line through eyelets from above the assembly point! Make sure that the climbing aid used (ladder or similar) is standing securely. The assembly of the winding core must be carried out by two people.

ATTENTION:



When installed, the cable outlet from the motor head must lead out at the top and continue downwards with an arc so that rainwater drips off the U-shaped cable arc!

Proceed:

- Have two people carry the winding core to the assembly site
- First mount the motor side, then the counter bearing side
- Insert square into fork on wall plate and secure from above and below with M10x16 screw. The cable outlet from the motor head must be routed out at the top and form a U-shaped curve downwards where rainwater drips off.
- Insert the counter bearing into the fork on the mast and secure it from above and below with an M10x16 screw.
- Secure screws / threads with Loctite

ATTENTION:

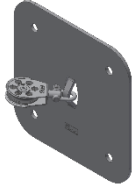
All screws for fastening the motor head and counter bearing must be tightened and secured with screw lock

		<p>Install line linkage blocks on wall plate.</p> <p>The line is guided by ball bearing blocks with swivels. The ball bearing blocks are attached to ring eyes or brackets (on poles and / or wall plates) via an integrated screw shackle.</p> <p>The standard line guide is as shown in section 4.3</p> <p>Individual line guides can be found in the planning documents (drawing).</p>
		<p>Height Adjustment</p> <ul style="list-style-type: none"> • Manual (Tackle) • Manual (winch) • Electric (tube motor) >> For details, see separate assembly instructions. <p>At the desired sail extension, an additional deflection block (with line leader) is threaded onto the extension line between sail and mast. The height adjustment of the sail is done via line leader, which is pulled down via a tack or winch.</p> <p>In the case of electric systems, the movement is effected via a spool driven by a tube motor (integrated in a profile tube which is mounted parallel to the extension mast). The winding axis and the height adjustment are operated by the same control system (Solexa II).</p> <p>>> up to max. 6m sail extension >> Only in combination with Solexa II control system >> Only for masts with D100</p>

5.4 Fill in the dimension sheet

	<p>When all attachment points (masts, wall plates) are installed, the base dimensions for sail production can be determined. When determining dimensions, please only use the standardized measurement sheets, which are available for every system type and installation variant.</p>
	<p>Proceed:</p> <ul style="list-style-type: none"> • Select dimension sheet >> see dimension sheets in the sunfurl.eu dealer area • If there is no suitable standard dimension sheet for the individual arrangement, please create a clear sketch (similar to the standard dimension sheets) and enter all dimensions there. • If anything is unclear, please contact your sales partner or Bartels directly!!! • Determine dimensions with a metal tape measure (2 people required) • Enter the dimensions in the dimension sheet • Enter mast heights in the dimension sheet • Enter name / BV + date on the dimension sheet • Specify desired color (possibly type of fabric) • Check dimensions (2nd measurement) <p>Scan or take a photo of the measurement sheet with the dimensions entered and email it to your SunFurl sales partner.</p>

Example of RES-A1 L measurement sheet



Measuring sheet SunFurl® RES

Sail up to 100 m² | Furling axis up to 14 m | Operation electric



SF-RES-A1

2 x wall | 2 x mast

(Pos. A left)

Please note when measuring:

- Determine distances to masts under slight tension
- Use a metal measuring tape (or similar without stretching)
- Enter the dimensions legibly and clearly on the measurement sheet
- Check dimensions with a second measurement

Building / wall

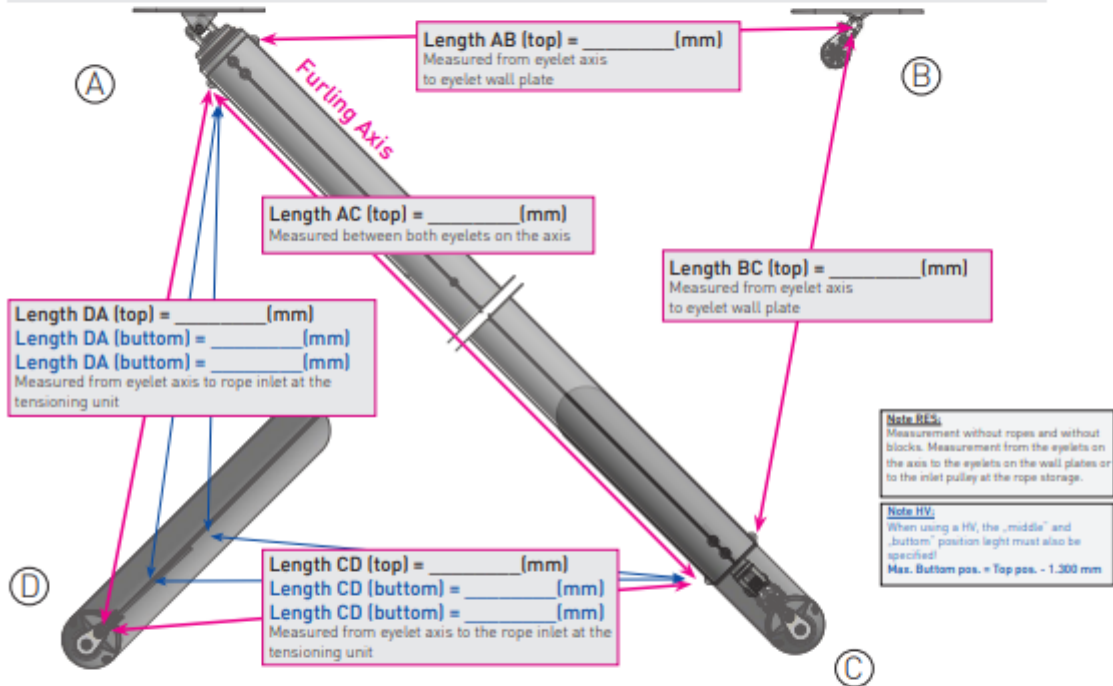

Note RES:
Measurement without ropes and without blocks. Measurement from the eyelets on the axis to the eyelets on the wall plates or to the inlet pulley at the rope storage.

Note HV:
When using a HV, the „middle“ and „bottom“ position height must also be specified.
Max. Bottom pos. = Top pos. - 1.300 mm

SunFurl® Measuring Sheet Rev. 01/2022. Errors and changes excepted.

Important - please note:

The measurement sheet must always be up-to-date!
The measurement sheet must be filled out completely and clearly!
The assignment of the measurement sheet to SunFurl® corresponds to a binding sail order (according to the data contained therein). Further subsidiary agreements (email, telephone) are not taken into account. No approval drawing is created / transmitted. The general terms and conditions of the BARTELS GmbH apply.

Supply of an approval sail drawing (29,49 EUR / net): YES

Project Details:

Name Reseller: _____
 Name Customer / BV : _____
 Date: _____
 Fabric Type: _____
 Fabric Color: _____

* OKF = Floor Level / Terrace Niveau / Uniform Level

	A	B	C	D
Height Measuring point top (from OKF*)				
Height Measuring point middle (from OKF*)				
Height Measuring point bottom (from OKF*)				
Free Length of Mast (above fixation)				
Ground Screw	<input type="checkbox"/>	<input type="checkbox"/>	<input type="checkbox"/>	<input type="checkbox"/>
Ground Sleeve	<input type="checkbox"/>	<input type="checkbox"/>	<input type="checkbox"/>	<input type="checkbox"/>
Ground Flange	<input type="checkbox"/>	<input type="checkbox"/>	<input type="checkbox"/>	<input type="checkbox"/>
Wall Clamping Flange	<input type="checkbox"/>	<input type="checkbox"/>	<input type="checkbox"/>	<input type="checkbox"/>
Height Adjustment	<input type="checkbox"/>	<input type="checkbox"/>	<input type="checkbox"/>	<input type="checkbox"/>
Wall Plate	<input type="checkbox"/>	<input type="checkbox"/>	<input type="checkbox"/>	<input type="checkbox"/>

Options

Adapt sail extensions: NO YES (A 0) YES (A 500) YES (A)
 WSH WSH = Winter Cover (HS1011) Remark: only for RE and RES systems
 WSS WSS = Winter Bag (HS1013) Remark: only for RM / RM-light / FX / FX-light systems



BARTELS GmbH
 Berghheimer Str. 26
 88677 MARKDORF
 GERMANY

Tel +49 (0)75 44 / 95860-0
 Fax +49 (0)75 44 / 95860-60
 http://www.bartels.eu
 info@bartels.eu

Managing director: Dr.-Ing. Florian Bartels
 Register court AG Freiburg: HRB 581061
 USt-IdNr. / VAT Reg. N° / TVA: DE811801546
 Terms and Conditions: www.bartels.eu/agb

Volksbank Friedrichshafen-Tettmang eG
 Konto 230597007 IBAN DE21 6519 1500 0235 5970 07
 BLZ 651 915 00 BIC/SWIFT GENODE33TET

5.5 Notes on the measurement sheet

When planning, the parameters described on the sheet must be taken into account. If these are not adhered to, the sail geometry may not be feasible and therefore the planned shading cannot be implemented. You can find more limit sizes in the sunfurl.eu retailer area.



Remarks on Sail measurements

IMPORTANT PLEASE NOTE

<p>Indication of measuring points above, middle, below</p>	<p>The specification of heights (above OKF) is relevant for the sail construction. Sails are constructed to the middle position. The measured values for top and bottom are required for determining dimensions and estimating the accessibility of the positions. In addition, cutting compensation and rainwater drainage are defined.</p> <p>The free length of a mast (over the clamp) is relevant for determining the resilience of the attachment point (flexion of the mast) and is therefore important for determining the dimensions.</p> <p>For RE / RES with HV, the maximum length of the sails can be 6m.</p> <p>With RE, the HV must not be installed on the mast with lenght compensation.</p>	<p>If the positions at the top and bottom are outside of a corridor of +/- 20° from the pulling angle of the middle position, they cannot be reached completely with certainty.</p> <p>Masts with HV should be installed 10° falling on the rope bisecting the angle and also falling with the angle of the furling axis. So that the pull angle changes as little as possible when adjusting the height. It is recommended to use lines to simulate the sail in order to determine the alignment of the sail extension mast when installing the foundations.</p> <p>Action: First mount wall plates and/or masts for the furling axis. At these points install a sail triangle made of lines up to the planned extension mast. Simulate the position of the pull-out point at HV above and below and orientate the mast position / mast inclination to it. Aim: as little deviation in the pull angle as possible when changing the height above the HV).</p>
<p>Indication of details on the type of attachment of masts</p>	<p>Determination of the flexibility of the attachment points. Relevant for defining dimensions.</p>	
<p>Different extension lengths / adjust draw length</p>	<p>With RE and RES systems only possible if the clew of the shorter sail is not rolled over by the cloth of the longer sail (observe clew orthogonals).</p> <ul style="list-style-type: none"> - In addition, a delta of max. 0.5m applies to RES and a delta of max. 1.0m applies to RE. - With RM systems, a maximum delta of 1.5 m is possible. - With RM-light systems, a delta larger than 0.5m should be avoided, otherwise the 2:1 rope guide on the clew will be blocked. 	<p>If the orthogonals on the winding axis through the clew of both sails are close together, a different sail pullout is not permitted! (see adjacent sketch)</p>
<p>Max. angle between spool axis and outer leech</p>	<p>70° must not be exceeded</p>	<p>Due to the strongly changing angle during the furling process, the sail is overloaded / overstretched in the area of the shorter leech</p>
<p>Rainwater drain Sail gradient Installation heights</p>	<p>A gradient of 15° must be maintained so that rainwater drainage is possible</p>	<p>Observe guide values for heights according to the system size. With a 30-40m2 system, the high point should be around 4m</p>
<p>Aspect ratio of a system (length and width) and Aspect ratio of a single sail (outhauls)</p>	<p>The aspect ratio of 1:1.5 must not be exceeded</p> <p>With RE systems, the sail extension must be at least 1.5m shorter than the furling axis!</p>	<p>Due to the hollow cut, which is proportional to the length of the leech, a strongly asymmetrical sail is created if the aspect ratio is exceeded. Due to the freedom of movement for the free 2:1 deflection block (above the winding axis)</p>
<p>Indirect determination of dimensions „Measure around the corner“</p>	<p>If a dimension cannot be measured directly with the tape measure (interfering contour), then the dimension must be determined indirectly according to the scheme on the supplementary sheet „Measure around the corner“!</p>	

SunFurl® Außenblat: Stand 01/2022. Irrtümer und Änderungen vorbehalten.



BARTELS GmbH
Berghheimer Str. 26
88677 MARKDORF
GERMANY

Tel +49 (0)75 44 / 95860-0
Fax +49 (0)75 44 / 95860-60
<http://www.bartels.eu>
bartels@bartels.eu

Managing director: Dr.-Ing. Florian Bartels
Register court AG Freiburg: HRB 581061
USt-IdNr. / VAT Reg. N° / TVA: DE811801566
Terms and Conditions: www.bartels.eu/agb

Volksbank Friedrichshafen-Tettngang eG
Konto 235597007 IBAN DE21 6519 1500 0235 5970 07
BLZ 651 915 00 BIC/SWIFT GENODE31TET

5.6 Measurement sheet "measure around the corner"

If a length cannot be measured due to an interference contour, this must be done other lengths can be measured.
This measurement sheet must be used for this.



Measuring sheet SunFurl® RES

Sail up to 100 m² | Furling axis up to 14 m | Operation electric



SF-RES-xx

"Measure around the Corner"

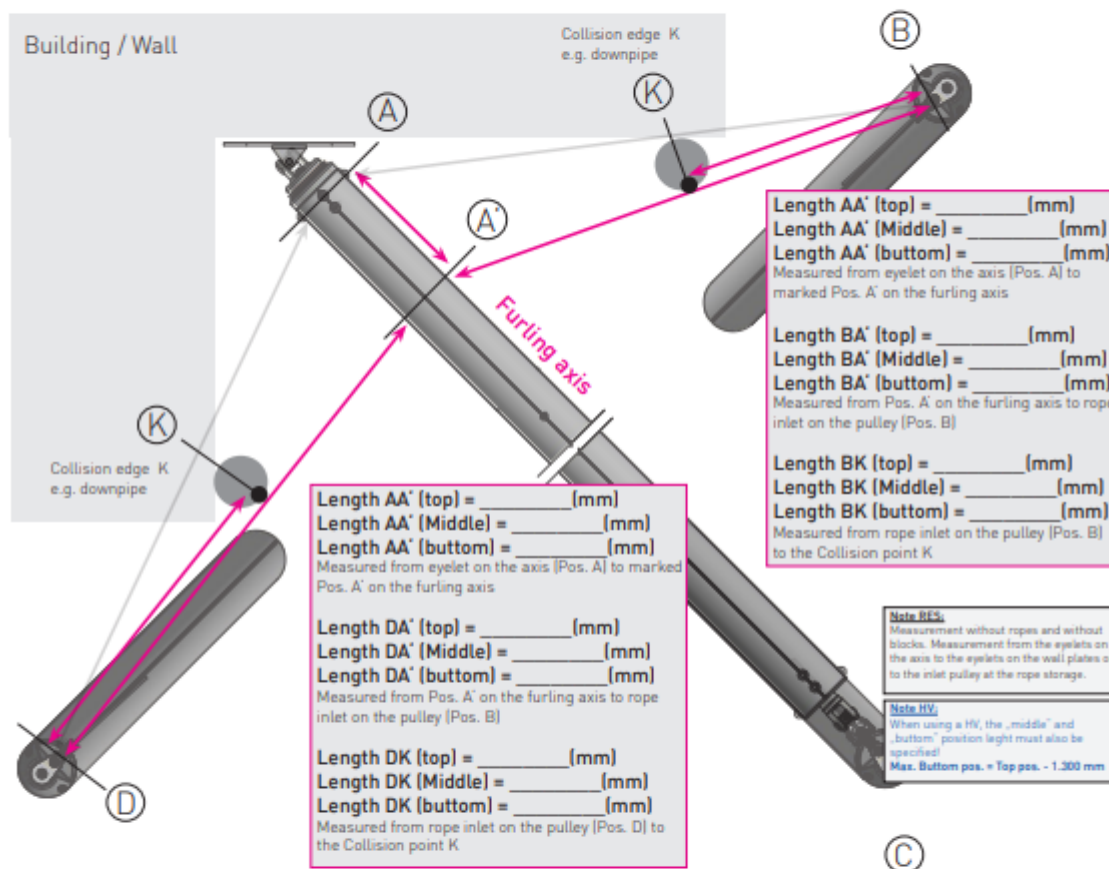

SunFurl® measurement sheet as of 01/2022. Subject to errors and changes.

Project Data:
Name Reseller: _____
Name Customer / BV : _____
Date : _____
Remarks:

„Measure around the corner“

If a dimension (here AB and/or AD) can not be direct measured, then the construction is over an auxiliary triangle required.

Action:

Fix the measuring tape at point B / D and lead it up to the furling axis. Move the tape along the furling axis until it is tangential to the collision point K [mark point A' on the furling axis]. Three additional measurements [per auxiliary triangle]. Determine the dimensions on the measurement sheet.















BARTELS GmbH
Berghheimer Str. 26
88677 MARKDORF
GERMANY

Tel +49 (0)75 44 / 95860-0
Fax +49 (0)75 44 / 95860-60
<http://www.bartels.eu>
bartels@bartels.eu

Geschäftsführer Dr.-Ing. Florian Bartels
Registergericht AG Freiburg HRB 581061
USt-IdNr./ VAT Reg. N°/ TVA : DEB11801566
AGB's unter www.bartels.eu/agb



Volksbank Friedrichshafen-Tettngau eB
Konto 235597007 IBAN DE21 6519 1500 0235 5970 07
BLZ 651 915 00 BIC/SWIFT GENODES1TET

5.7 Connect the product to the power supply



	<p>All work on live components and supply lines may only be carried out by a trained electrician.</p> <p>The low-voltage guidelines must be observed during installation!</p>	
		<p>The supplied safety switch must be placed and connected in an easily accessible location near the awning roll system. The safety switch must disconnect the rolling mechanism (motor) in the 0-position all-pole with at least 3mm contact opening width from the power supply.</p> <p>Unintentional starting of the rolling mechanism must be prevented by the safety switch (maintenance, installation, holiday). Similarly, in case of malfunction an immediate stopping of the rolling process by interruption of the power supply (switch in zero position) must be ensured.</p>
 		<p>The hub for the motor head of the hub has an M5 threaded hole for attaching a protective conductor. This must be connected to at least one side in order to keep all metallic surfaces of the rolling system (including all related fasteners, masts, line guide elements) in the event of a fault in the drive throughout stress-free.</p>
		<p>The awning roller system (tubular motor, optional sensor electronics, wiring) must be protected in a circuit of the house electronics via a FI (residual current circuit breaker)!</p>
		<p>The parallel operation of two drives can be carried out via the weather station relay (max 6A).</p> <p>With 3 or more drives, isolating relays must be provided.</p> <p>In home control systems, each drive is typically integrated as an independent subscriber (parallel operation is programmed as required)</p>
		<p>The cable of the motor must not be loaded with traction during installation and operation. The cable must be routed so that it is not caught / touched by moving parts of the hub or by cables during operation.</p>
		<p>The drive must be operated via a weather control in order to retract the sail automatically when the wind picks up /downpours / snow.</p> <ul style="list-style-type: none"> • Standard weather control (scope of delivery) • Any house control with wind / rain sensor / temperature sensor



6 Commissioning

6.1 Preparatory work for switching on the rolling mechanism

	<ul style="list-style-type: none">• During initial commissioning, no sail and no line guide may be installed on the winding core!• The winding core must be fixed stably on both sides (for details see section Fehler! Verweisquelle konnte nicht gefunden werden.)• Has the electronics been installed by a specialist? Is the main switch, FI, control element and weather sensors installed and easily accessible?• If a sensor control has been installed, it must be set to "Manual" sail operation during initial startup (to prevent unintentional startup of the drive).• Check whether the winding core can move freely (remove all objects / cables from the rotating area of the winding core)
	

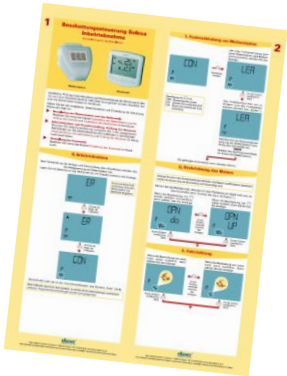

6.2 Switching on the product (with Solexa radio control)





	<ul style="list-style-type: none">• Define in advance the desired direction of roll in and out (this is required during the further installation process - sketch on a piece of paper is helpful).• Obtain the quick guide of the Solexa controller (yellow leaflet) and follow the installation steps exactly.
	
	
	
	<ul style="list-style-type: none">• After switching on the safety switch, the winding core immediately begins to rotate (radio link has not yet been learned). It is recommended that the first steps (Solexa instructions) for teaching in the radio link be processed quickly, so that the movement can be stopped manually (and from this point on a targeted operation of the rolling process can take place).• Once all the steps in the quick guide have been completed and the settings have been saved, it is recommended to switch off the weather sensors (wind, rain) for the duration of commissioning, so that the winding core does not start to spin unintentionally. As long as no limit switches have been set on the drive, the winding core will continue to rotate without limit if the weather sensor is active (in the case of a wind or rain alarm)!• Hold down the set button 3s on the control panel to enter the settings menu. Further pressing of the set button jumps to the next value. Save at the end of the values with SAV settings.
	<p>The following recommended starting values for putting the system into operation (see also Solexa control manual):</p>
	<ul style="list-style-type: none">o A> Light intensity (kLux) with arrow key down to OFFo B> Extension delay (not relevant if A is OFF)o C> retraction delay (not relevant if A is OFF)o D> Internal temperature lock (° C) with arrow key down to OFFo E> Outdoor temperature lock (° C) with arrow key down to OFFo F> Wind alarm (m / s) with arrow key down to OFFo G> Rain alarm with arrow key down to OFF

	<p>To check (in manual mode):</p> <ul style="list-style-type: none"> • Movement of the winding core can be started and stopped? • winding core turns freely? • winding core turns without any noticeable noise? • The drive cable is free of moving parts (and without tensile load)? • winding core rotates in the right / desired direction for rolling in or out? (Corresponding sketch on a piece of paper) • Safety switch works (rolling process in zero position of the switch by hand / radio / sensor not possible)?
	<p>ATTENTION: Tubular motors tend to overheat</p> <p>The tubular motor is not designed for continuous operation. Normally his job is to roll out the sail once and curl up after a few minutes at the earliest. During setup, however, it is necessary for the tests and adjustments to move the sail often in a short time. The built-in drive has an extended running time compared to standard drives (8 minutes continuous operation / 8 minutes cooling off).</p> <p>DANGER:</p> <ul style="list-style-type: none"> • The engine automatically shuts off for a few minutes when a temperature limit is reached. In this cooling time, no operation of the drive is possible • We recommend only carrying out the necessary movements with the drive and allowing a few minutes for the drive to cool down between the rolling processes. • After 8 minutes of movement, the drive needs at least 8 minutes rest

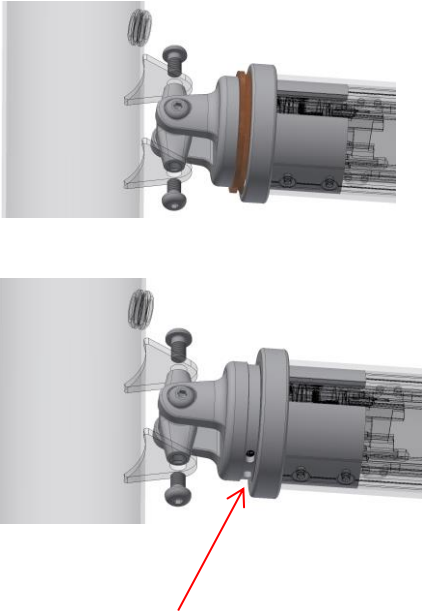
6.3 Setting up / adjusting the product

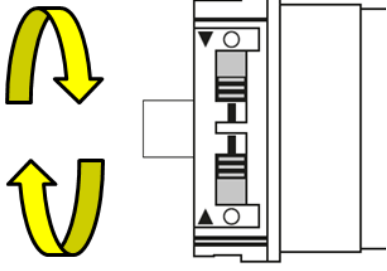
6.3.1 Adjust the limit switch / retract the sail

 		<p>Adjust limit switches</p> <p>The limit switches are located under the seal on the motor head. Use a round object to carefully loosen the sealing ring on the engine head from the groove. You can reach the limit switches through the two holes with a small screwdriver.</p> <p>ATTENTION: Move switch carefully (sensitive). Make sure that switches are always in a clear position. Only move the switch across the winding core!</p> <p>Further / detailed information on adjusting the limit switches can be found in the product description of the BECKER tubular drive. Please refer section 12.4.1</p> <p>Proceed:</p> <ul style="list-style-type: none"> • First delete both end positions (push both switches outwards to the delete position, issue a short travel command) • Move the winding core to the position that corresponds to the later unrolled state (align the piping groove horizontally) => set the extended end position • Check whether the movement stops as desired (extended state)! If the movement does not stop, the end position has not been set correctly (switch position) or the wrong end position switch has been set! In both cases it is recommended to restart the procedure completely (delete end positions) <ul style="list-style-type: none"> • If the winding core stops as desired, the sails can now be pulled into the keder grooves. Connect the sail extensions
--	---	--

	<p style="text-align: center;">Linkslauf Endlagenschalter</p>  <p style="text-align: center;">Rechtslauf Endlagenschalter</p> <p>  Programmier-Stellung Schalter Lösch-Stellung Drehrichtungspfeile </p>	<p>(clews) to the snap hooks of the line storage. If necessary, reposition the snap hooks on the line beforehand so that the maximum force of the line storage is built up when the sail is extended</p> <ul style="list-style-type: none"> • For the E2 arrangement, observe Section 6.3.2 for installing the GRP extension tube • Furl the sail completely (do not over-tighten) • The second limit switch (retracted state) can now be set.
	<p>Test the installed sun sail in manual mode and check the behaviour of the sail and the lines.</p> <ul style="list-style-type: none"> - Lines must not graze / be obstructed anywhere. - Lines must run smoothly through all ball bearing blocks. - The sail must always be under tension during furling. - The tension of the piping can be used to eliminate wrinkles in the sail. - The sail should furl as smoothly as possible over the furling core. - The end position switches must respond reliably in the furled and unfurled state. - If the sail behaves without problems when operated manually, the automatic mode can be tested. 	
	<p>Carry out a test of the installed sun awning in automatic mode and check the behaviour of the sensor system.</p> <ul style="list-style-type: none"> • Switch to automatic mode and programme the sensor control • <u>The following are the recommended start values for putting the system into operation in automatic mode (see also the Solexa control manual):</u> <ul style="list-style-type: none"> o A > Light intensity (kLux) = 20 kLux o B > Extension delay = 10 min o C > Retract delay = 10 min o D > Indoor temperature lock (°C) = OFF o E > Outdoor temperature lock (°C) = 5 °C o F > Wind alarm (m/s) = 7 m/s o G > Rain alarm = ON <p>Simulate wind or rain at the sensor unit to trigger the furling command. Does the sail furl (is the winding direction correct)? The reaction direction can be turned in the weather control menu (see Solexa weather control manual).</p> <p>The values of the sensor control must be adjusted individually. In the days/weeks after installation, take some time to study the behaviour of the sail in different weather conditions and, if necessary, adjust individual values according to your wishes.</p>	
	<p>DANGER:</p> <p>Observe the behavior of the rolling system in the first days after installation exactly.</p> <ul style="list-style-type: none"> • Strip linen in any places? • Are all mounting points stable? • Is the sail always taut? • Does the sensor unit react to wind / rain in time (and in the right direction)? 	

	<ul style="list-style-type: none"> • Are noticeable noises during the rolling process? <p>Please contact your local distributor / installer or BARTELS GmbH immediately in case of any problems / questions.</p>

6.3.2 Montage GFK Auszugrohr (nur bei E2 Anordnungen)

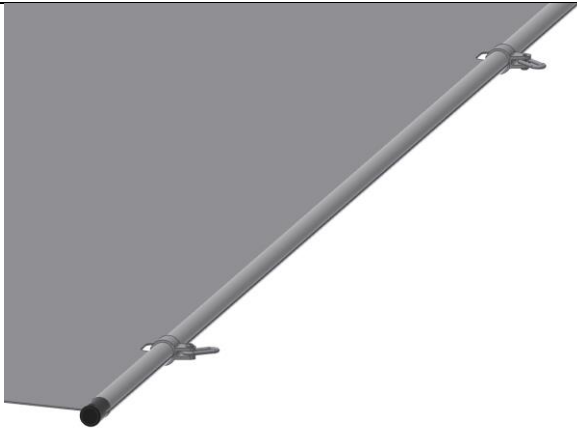
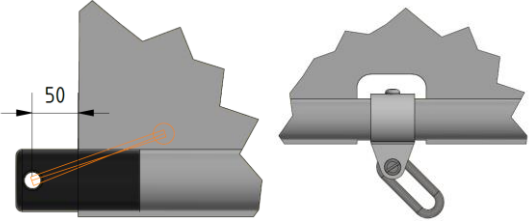
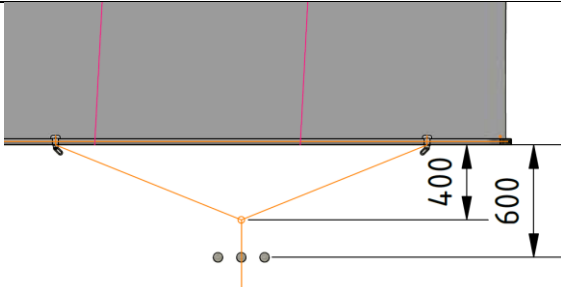
	<p>Join GRP pipe elements with connectors (use the supplied 2-component adhesive)</p>
	<p>Guide the GRP pipe through the hemstitch In the area of the cutouts, the connection lugs Slide on (fix on the tube later)</p>
	<p>Adjust the length of the GRP pipe so that the POM end connections protrude approx. 50mm.</p> <p>Position the connection lugs in the middle of the recesses in the sail and fix them with the locking screw.</p> <p>ATTENTION: Pre-drill, do not screw the screw into the GRP (risk of tearing the tube)</p>
	<p>Attach the pull-out line to the clamping lugs using a triangle. The triangle must have a depth of at least 400mm. The distance to the mast must be at least 600mm when extended.</p>

6.3.3 Threading the rope into the rope store

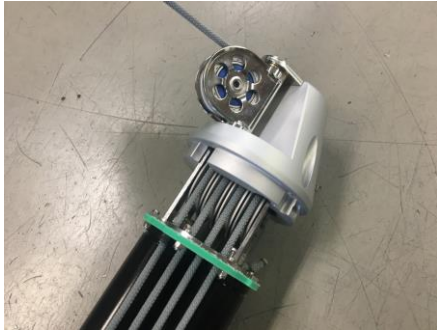

When delivered, the line is already threaded into the line storage. Should it be necessary to pull the pull-out line into the line store, the following steps are required:

- Pull the line storage up and out of the mast (loosen the screws, release the tension, do not damage the piston rods)
- Completely remove old line from line storage
- Dismantle the head of the line storage (4 x M6 Torx countersunk screws on the side)
- Pull new line into the line store (line must be guided freely over all pulleys through all openings)
- Lead the line through the head of the line store, unscrew the head and insert the line store back into the mast

REGARD:

Make sure that the line is not twisted! After installing it in the mast, check whether the line runs smoothly in the tube (pull out one meter of line from the line storage with the trimming handle).

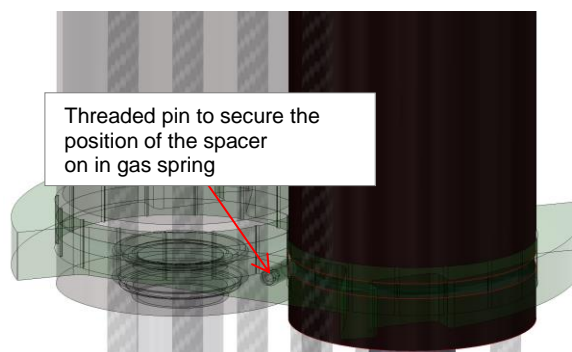





6.4 Winter Protection Cover

	<p>Install winter cover</p> <ul style="list-style-type: none"> • Furl the sail completely
--	---

	<ul style="list-style-type: none"> • Switch the main switch / fuse to OFF • Place the winter protection cover over the sail (on the axle). • Close the Velcro fastener • Fasten the cover to the motor head and to the counter bearing • Slightly tie the sail including the cover together at 3-4 points with the silver additional lines (more compact / less windage surface)
--	--

6.5 Stop and switch off the product



		<ul style="list-style-type: none"> • During commissioning, the rolling system may only be operated in manual mode. Tapping forward or back will spin the reel and roll the sail in and out. • After installation, the system is typically operated in automatic mode. The sensor system decides according to your measured values and the programmed threshold whether the sail should be retracted or extended.
		<ul style="list-style-type: none"> • To turn off the system (i.e., completely disconnect it from the power supply), the safety switch must be set to zero. • In emergency situations, the safety switch can always be reset to zero • If possible, it is advisable to set the safety switch to zero position when the sail is rolled up, so that the sail cannot pose any danger (due to overloading) in the event of wind and rain!

7 Operation

7.1 Switch on the system

	<ul style="list-style-type: none">• Make sure that the rolling system is free of objects• Make sure there are no obvious signs of damage.<ul style="list-style-type: none">○ Check wall and mast fundamentals○ Check the winding core○ Check the line guide○ Check sails
	<ul style="list-style-type: none">• Position the safety switch in the ON position• If the sunshade is connected to a sensor control (and in automatic mode), a movement (roll in or out) can already be carried out after switching on the safety switch (usually delayed by 1-x minutes according to the set delay times). If this is not desired, immediately switch the sensor control to manual operation after operating the safety switch

7.2 Operating the system

	<ul style="list-style-type: none">• Put the sunshade in automatic mode (mandatory), so that the sensor control system automatically retracts the sun sails in the event of excessive wind and rain and automatically exhausts if the weather conditions improve and the sun shines again• Operating the awning in manual mode via a sensor control (roll in / out as required). In case of excessive wind and rain, roll up the awning in good time to avoid damage to the roll system, sails and attachment points. Make sure that the manual operating mode switches back to automatic mode !!• Operate awnings with a simple switch and roll in / out as required (not recommended). In case of excessive wind and rain, roll up the awning in good time to avoid damage to the roll system, sails and attachment points
	<ul style="list-style-type: none">• In the event of a fault, immediately set the safety switch to zero and search for the cause of the fault. Typical fault conditions are described in Section 8-41.• If necessary, contact the installer of the system or BARTELS GmbH for assistance with the elimination of fault conditions!

7.3 Restart the system after an interruption

	See section 7-40
--	----------------------------------

7.4 Stopping / switching off the system

	<p>It is recommended in case of prolonged absence (eg winter months, holidays, etc.) to switch off the awning when it is rolled up via the safety switch.</p> <ul style="list-style-type: none">• Roll up the awning• Set safety switch to zero position• Secure safety switch against unauthorized switching on (lock)
---	---



8 Fault states

8.1 Errors / error causes / trouble shooting

Errors	Error causes	Trouble shooting
Drive does not move	In the event of an overload, the drive becomes hot and switches itself off at a certain limit temperature. After a few minutes of cooling, the drive is ready for use again.	Remove cause of error (blockage by backrest, ...) After a few minutes cool down, try again Follow the instructions of the manufacturer, see section 12.4.1
„Scraping“ sounds when moving	Leash runs out obliquely / over a roll	Align rollers
„Squeaky“ sounds when moving	Ball bearing defective	Determine affected bearing + exchange Possibly. Consultation with BARTELS
Awning does not respond to control (radio control)	Battery in radio control unit empty?	Replace battery in radio control unit
	Distance between transmitter and weather station too big?	Shorten distance between hand transmitter and weather station
	Safety switch off?	Safety switch switch on the awning
	Drive overheated?	Wait a few minutes. After cooling, the drive reacts again

9 Maintenance

9.1 Maintenance instructions for your safety





	<p>Before any maintenance work, the safety switch must be set to zero to avoid that the rolling system is set in motion by a sensor control or unauthorized persons!</p>
	<p>Maintenance activities may only be performed by instructed persons!</p> <p>Safety equipment must be worn during maintenance work (gloves, goggles) During maintenance, all uninvolved persons must leave the danger area of the reel, ropes and sails.</p>

9.2 Maintenance after switching off the system

	<p>Checking all lines of the sail guide</p> <ul style="list-style-type: none"> • wear • scraping parts • After 3 years at the latest, all guide lines must be replaced due to UV damage
	<p>Winding core, bearings and fasteners</p> <ul style="list-style-type: none"> • Deflection winding core • stability attachment points (on walls, parapets, etc.) • Noticeable noise when moving
	<p>Check sail for damage</p> <ul style="list-style-type: none"> • cracks • scraping parts • Stains can be removed as needed by cleaning the sail. • Sails may only be worked by a professional cleaning. Talk to your SunFurl® sales partner or BARTELS GmbH for a recommendation.
	<p>Check mast foundations</p> <ul style="list-style-type: none"> • Damage to concrete foundations (ground pods) • Stability of ground anchors / ground sleeves • Locking screws on ground sleeves • Plug-in depth of mast tubes (the masts have changed the insertion depth by at least 500 mm due to vibrations / external forces) • kinking on mast pipes (especially at the upper edge of ground anchors or ground pods)

10 Decommissioning, disposal

10.1 Decommissioning, disassembly and storage

 	<p>Remove rope guide from sail</p> <p>ATTENTION: Maintenance activities may only be performed by instructed persons! Disassembly work must always be carried out by two persons</p> <p>ATTENTION: Leash is preloaded by spring of the length compensation. When disassembling the leash (at high speed) is pulled into the masts until the spring has relaxed.</p> <p>ATTENTION: Sail falls down when removing the lanyard. Make sure that there are no persons and sensitive or sharp objects underneath.</p> <p>Action:</p> <ul style="list-style-type: none">• Switch sensor control to manual control mode• Position the sail in the lowest tension position on the leash (usually between half and full retracted)• Take the tension off the leash with a trim handle (1st person)• Open the shackle on the sail and slowly release the tension by following the trim handle in the direction of the force (2nd person)• As soon as the tension is completely relieved, the line guide can be dismantled without danger
 	<p>Dismantle the sails and the hub</p> <p>ATTENTION: Maintenance activities may only be performed by instructed persons! Disassembly work must always be carried out by two persons</p> <p>ATTENTION: Electrical work may only be carried out by a specialist</p> <p>Action:</p> <ul style="list-style-type: none">• Unroll the sail completely and remove it from the piping rail (Keder liek remove trim lines first)• Store the sails dry and separate from the hub• Release the cable at the hub (so that it does not interfere with the removal of the hub). To do this, the motor cable must be disconnected from the weather station or a junction box. Electrical work must be carried out by a qualified electrician!• Unscrew the winding core (observe the instructions in the assembly instructions in the reverse order from section Fehler! Verweisquelle konnte nicht gefunden werden).• Store the winding core in a protected position (with the least possible deflection). Make sure that water can collect in the area of the drive (store drive side up). Secure against rolling.• Remove the wall bracket from the walls
	<p>Dismantle masts</p> <p>ATTENTION: Maintenance activities may only be carried out by instructed persons! Dismantling work must always be carried out by two persons</p> <p>Procedure:</p> <ul style="list-style-type: none">• Follow the instructions in the assembly instructions in reverse order from section 5.2.• Remove the masts from the ground sockets / screw foundations (loosen the securing screws on the foundations).• Store all parts in a protected place. Secure against rolling

10.2 Recommissioning after shutdown

	See in section 5
--	----------------------------------

10.3 Disposal after disassembly

	<ul style="list-style-type: none">• All metallic parts (winding core, bearings, wall brackets, etc.) can be disposed of as steel / aluminium scrap.• Separate the electronic components (drive, weather sensors) from the steel parts and dispose of them in the electrical scrap.• The gas springs from the line accumulators must be depressurized before disposal. It is strongly recommended to send gas springs to your local dealer or to BARTELS GmbH (for professional disposal).• Ropes and sails can be disposed of with the residual waste• For materials included in the product, see list in section 3.7
--	--

11 Warranty

11.1 Warranty Period

	<ul style="list-style-type: none">• The warranty period begins on delivery of the product (date of delivery note)• The warranty only applies to the components supplied by BARTELS (delivery note)• The warranty period for all mechanical components is 36 months (excluding wearing parts and electrical components - see also section Fehler! Verweisquelle konnte nicht gefunden werden.)• The warranty on wearing parts (leashes, sails) is 12 months• The warranty for drive and weather control is 12 months
--	---

11.2 Wear parts

	<ul style="list-style-type: none">• Ropes• Sail
---	--

11.3 Disclaimer

	<p>Excluded from the warranty</p> <ul style="list-style-type: none">• Assembly errors and their consequences• Damage resulting from improper use of the product• Damage resulting from overloading the product• Damage caused by unauthorized modifications to the product
--	--

11.4 Processing of a warranty claim

	<p>In the case of warranty claims within the warranty period, please contact your SunFur® sales partner (and / or BARTELS GmbH) to plan the processing.</p> <p>For contact details see delivery note or imprint of this document</p>
--	--

12 Attachment

12.1 Arrangement plan



Most roll systems are individually adapted to the structural conditions. An exact installation plan must be provided by the planning company / person (sailmaker, awning builder, architect, etc.).

In any case, before the start of construction, a detailed plan should be prepared at which points fastening points must be placed (wall fasteners, ground anchors, bracing, concrete foundations, etc.).

The condition of wall, floor, etc. must be suitable for the attachment of the foundations suitable! The fastening elements (screws, dowels, etc.) must be suitably selected according to the substrate!

12.2 Forces / Fasteners

12.2.1 Forces / General



ATTENTION: Forces (on wall panels, ground foundations, winding core, lines) increase considerably when the wind picks up, which can affect the extended sail. It is imperative to provide an automatic control system that retracts the sail when the permissible wind speed is exceeded!

The permissible wind speed for which the sun sail system is designed is :

- Up to 9 m D86 wave > 6 Bft (max. 45 km/h or 12.5 m/s)
- Up to 10 m D102 wave > 6 Bft (max. 45 km/h or 12.5 m/s)
- Up to 12 m D102 wave > 5 Bft (max. 35 km/h resp. 10.7 m/s)
- Up to 14 m D102 wave > 4 Bft (max. 25 km/h resp. 6,9 m/s)

ATTENTION: The wind speed determined in the area of the weather sensors does not always correspond to the wind speed at the location of the sun sail! If possible, the sensor system must be free-standing and installed in the area of the sun awning. During the first weeks/months after the installation of the system, observe how the sail behaves in changing weather conditions. If necessary, correct the wind speed limit value if the sail retracts too early or too late.

In general, if the wind entering the sail pulls the line more than 10-15 cm out of the length compensation (spring is tensioned / sail rises), then the sun sail must be rolled up (the weather control system must respond/be programmed according to this limit behaviour).

Note that this must not only apply to the predominant wind direction at the installation site, but also to all other wind directions. For example, your own or other houses/ trees/ etc. are not effective as wind protection for every wind direction!

ATTENTION: The sun awning must not be operated in the rain. Water pockets in the sail can overload/damage the system. Exceptions are installations where sufficient slopes have been provided for safe drainage. For safe drainage, a high tension of the sail, a flat cut of the sail and a continuous slope of min15° are required.

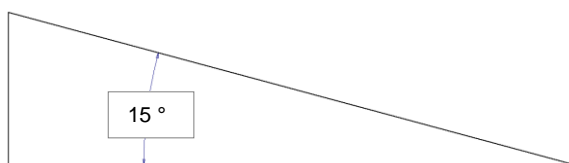

	<p>ATTENTION: The awning must not be operated at temperatures below 5 ° C. Ice and snow can overload / damage the system.</p>
--	--

12.2.3 Select dowels and screws for wall fixings correctly



ATTENTION: The distributor / installer is responsible for the choice of suitable fasteners, which are adapted to the substrate. Screws and dowels are not included with BARTELS

Action:

- Determine the base (wall, floor) to which the foundations are to be fastened (concrete, stone, solid stone, hollow stone, insulating layer, etc.)
- Find out about suitable fastening solutions in a specialized market (you will find information on fasteners typically used by BARTELS below)
- Follow the manufacturer's instructions for using the screws / dowels / foundation systems



Cracked concrete / hollow brick / solid brick (without insulation)

ATTENTION: The fastener described below is an example!
The sales partner or installer is solely responsible for the selection of the suitable fastener (adapted to the conditions at the installation site) and the installation according to the manufacturer's specifications!

- z.B.
FISCHER **FIS H K** Injektions-Ankerhülsen
FISCHER **FIS A** Ankerstange (Ausführung in A4)
FISCHER **FIS V** Hochleistungsmörtel

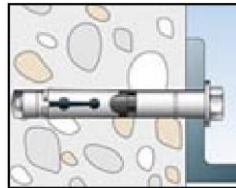

Cracked concrete / hollow brick / solid brick (with thermal insulation)

ATTENTION: The fastener described below is an example!
The sales partner or installer is solely responsible for the selection of the suitable fastener (adapted to the conditions at the installation site) and the installation according to the manufacturer's specifications!

- z.B.
FISCHER **Thermax** (Ausführung in A4)
FISCHER **FIS V** Hochleistungsmörtel
FISCHER **KD** Multi Kleb- und Dichtstoff

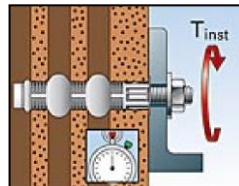

12.3 Circuit diagram SunFurl pipe® 230V



ATTENTION: Electrical work may only be carried out by a specialist



ATTENTION: Further information on the weather control and the drive must be observed. See separate installation / operating instructions of the manufacturer

ATTENTION: For parallel operation of several drives, a group relay must be provided! The direct parallel operation of drives on the weather control is not permitted!

230V AC tubular drive in conjunction with standard weather control

Controll Solexa I / Solexa II (Elsner)
Electric Drive 230V / AC (Becker)

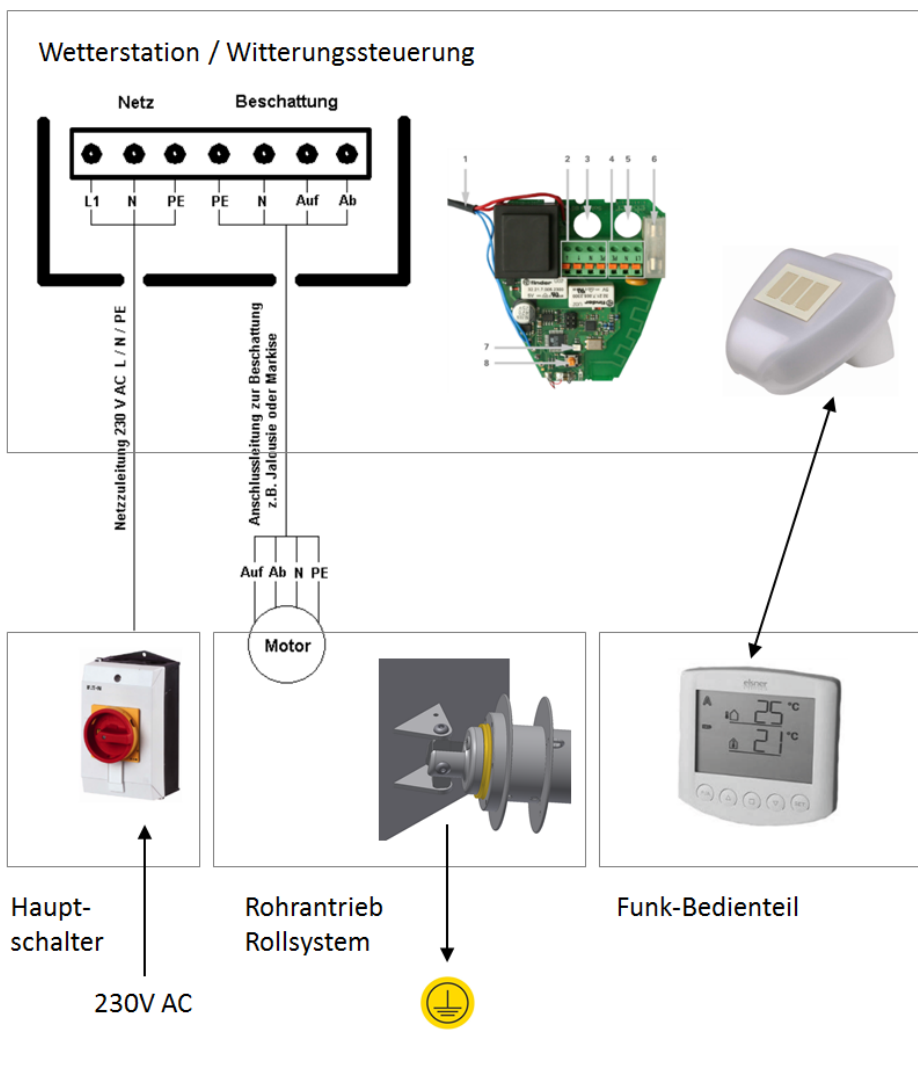

12.4 Operating instructions for 3rd party components

12.4.1 Tube drive 230V AC (L70/17.L80/11 E23 Fa. Becker)

	<p>See separate instructions (part of the delivery)</p>

12.4.2 SOLEXA sensor control / radio control

	<p>See separate instructions (part of the delivery)</p>

13EG – Declaration of conformity

- Valid for delivery of complete systems (winding core, wall panels, masts, line guide)
- Valid only for delivered components (without mounting material and mounting)

BARTELS GmbH
Bergheimerstraße 26
88677 Markdorf
GERMANY



Tel: +49 (0) 7544/ 95860-0
Fax: +49 (0) 7544/ 95860-60
bartels@bartels.eu
www.bartels.eu

EG – Konformitätserklärung

- Hiermit erklären wir, dass das Produkt „SunFurl RE“ allen einschlägigen Bestimmungen der Maschinenrichtlinie 2006/42/EG entspricht.
- Die Anforderungen gemäß EMV-Richtlinie 2014/30/EU sowie die Schutzanforderungen der Niederspannungsrichtlinie 2014/35/EU werden eingehalten.

Produktbezeichnung:

**Sonnensegelsystem „SunFurl RES“ (Ø86 / Ø102 Aluminium Wickelachse)
Antriebsversion 230V AC/ 50Hz**

Nur gültig:

- Für einbaufertig gelieferte Systeme (Wickelkern, Stützen, Wandplatten, Spanntechnik, Leinenführung)
- Bei Einhaltung aller Anweisungen der Betriebsanleitung
- Bei Verwendung des Produkts ohne Veränderungen
- Bei bestimmungsgemäßer Verwendung des Produkts

Zudem wurden folgende harmonisierten Normen angewandt:

DIN EN ISO 12100:2010	Sicherheit von Maschinen - Allgemeine Gestaltungsleitsätze Risiko- beurteilung und Risikominderung
DIN EN 60204-1:2007	Sicherheit von Maschinen – Elektrische Ausrüstung von Maschinen Teil 1
DIN EN ISO 13857	Sicherheit von Maschinen – Sicherheitsabstände gegen das Erreichen von Gefährdungsbereichen mit den oberen und unteren Gliedmaßen

Markdorf, 27.04.2020

Dr.-Ing. Florian Bartels
Geschäftsführer

